

# Table of contents



## **LED Retrofit Kit** p 218 - 221



- For EXIT signage  
Convert high consumption incandescent and fluorescent lamps to energy efficient LED lamps

## **RSF & RSFSP** p 222 - 223



- Fluorescent inverters

## **RSFSP/U/1100** p 224 - 225



- Fluorescent inverters

## **Wire Guards & Mounting Shelves** p 226 - 227



- Metal Protection for Exit signs, Battery units and Remote fixtures

## **NEXUS®** p 228 - 229

NEXUS - Network Management System

# LED Retrofit Kits

## for EXIT signage



### Convert high consumption incandescent and fluorescent lamps to energy efficient LED lamps.

Converting existing exit signage from incandescent or fluorescent lamps to LED (light emitting diodes) lamps drastically reduces operating and maintenance costs for building owners and property managers. As part of energy efficiency programs, some Canadian electric utilities are also actively promoting conversion to LED with incentive and rebate programs for installers and building owners/managers.

## Features

### Lumacell offers four retrofit kit options:

- **Superstrip Series**  
(red **AllnGaP** technology)
- **Mini-Wedge LMW Model**  
(red **AllnGaP** technology)
- **Mini-Wedge LMW XD Model**
- LED Lamp

### Here are some of the benefits of using LED lamps in exit signs:

- Exceptional energy efficiency – reduces energy consumption by up to 90%
- Extremely long life – 10 to 25 years
- Important reduction in maintenance and energy costs
- Average payback is less than two years (see page 6)
- Retrofit kits are easy to install
- Improved visibility and reliability



## Typical Specification

Converting existing exit signage from incandescent or fluorescent lamps to LED (light emitting diodes) lamps drastically reduces operating and maintenance costs for building owners and property managers.

As part of energy efficiency programs, some Canadian electric utilities are also actively promoting conversion to LED with incentive and rebate programs for installers and building owners/managers.

Project / Location		Date
Contractor		Prepared by
LUMACELL Model		



# LED RETROFIT KITS

## SUPERSTRIP Series (LMR model)



- Quick and easy to install
- Long-life, energy-efficient red ALINGAP LED technology
- Module features two independent circuits – one for AC input; one for DC input
- Universal AC input: 120/277/347Vac; universal DC input: 6 to 24Vdc
- Power consumption of 1.1W per module
- 10 year limited warranty

### Power Consumption

Model	AC Specs		DC Specs	
<b>LMR</b>	120/277/347Vac	1.1 W	6 to 24Vdc	1.3 W

### Dimensions

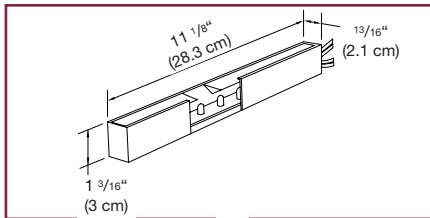

### Ordering Information

Series	Voltage	Options
<b>LMR</b> = hardwire retro-fit kit	<b>UNIV</b> = 120/277/347Vac, 6/12/24Vdc	<b>Blank</b> = 11.0" (28cm) long
	<b>UNIV36</b> = 120/277/347Vac., 36Vdc	<b>*-9.5</b> = 9.5 " (24 cm) long
	<b>UNIV48</b> = 120/277/347Vac, 48Vdc	
	<b>UNIV120</b> = 120/347Vac, 120Vdc	
	<b>120VACDC2</b> = 120Vac, 120Vdc, 2 wires	

**EXAMPLE: LMRUNIV**

## MINI-WEDGE Series (LMW model)



- Easiest to install in its class
- Compact size makes it ideal for virtually all exit signs
- Can be retrofitted directly on fluorescent ballast
- Long-life, energy-efficient red ALINGAP LED technology
- Available with AC adaptor for all type of lamp sockets
- 10 year limited warranty

### Power Consumption

Model	AC Specs		DC Specs	
<b>LMW</b>	120Vac; 86Vac step down from 347Vac	1.7 W	N/A	N/A

### Dimensions

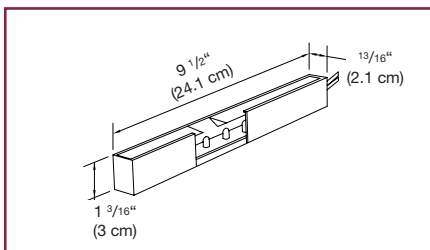

### Ordering Information

Series	Voltage	Base
<b>LMW</b> = for std applications	<b>120</b> = 120Vac	<b>C</b> = candelabra
	<b>120HW</b> = 120Vac, hardwire	<b>I</b> = intermediate
	<b>240HW</b> = 240Vac, hardwire	<b>M</b> = medium
	<b>277HW</b> = 277Vac, hardwire	<b>B</b> = bayonet
	<b>347HW</b> = 347Vac, hardwire	<b>F</b> = G23 compact fluorescent
		<b>CIMB</b> = complete set of bases (exclude "F" base)
		<b>CIMBHQ</b> = Hydro-Québec set for "Efficient Products Program".

**EXAMPLE: LMW120C**

## MINI-WEDGE Series (LMWXD model)



- Easiest to install in its class
- Compact size makes it ideal for virtually all exit signs
- Can be retrofitted directly on fluorescent ballast
- Suitable for all AC line applications including exit signs equipped with in-line diodes

## Power Consumption

Model	AC Specs		DC Specs	
<b>LMWXD</b>	120Vac; 120Vac with in-line diodes	2.8 W	N/A	N/A

## Dimensions

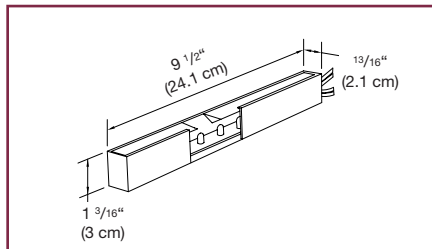

## Ordering Information

Series	Voltage	Base
<b>LMWXD</b> = with or without in-line diodes. high brightness	<b>120</b> = 120 Vac	<b>C</b> = candelabra <b>I</b> = intermediate <b>M</b> = medium <b>B</b> = bayonet <b>CIMB</b> = complete set of bases

**EXAMPLE: LMWXD120-C**

## LED LAMPS

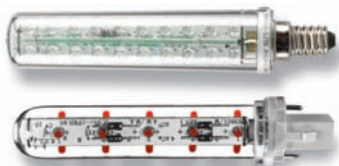

- Quick and easy to install
- Available with wide range of lamp bases for quick lamp to lamp replacement
- 120Vac or 120Vac with in-line diode

## Power Consumption

Model	AC Specs		DC Specs	
<b>L11W</b>	120Vac	0.90 W	N/A	N/A
<b>L3</b>	120Vac	2.6 W	120Vdc	2.6 W

## Dimensions

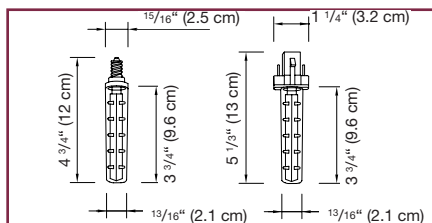

## Ordering Information

Series	Base
<b>L11W</b> = standard version	<b>C</b> = candelabra
<b>L3</b> = with or without in-line diodes (2.5W)	<b>I</b> = intermediate
	<b>M</b> = medium
	<b>B</b> = bayonet
	<b>F</b> = G23 compact fluorescent

**EXAMPLE: L1-1W-C**

Project / Location		Date
Contractor		Prepared by
LUMACELL Model		



# LED RETROFIT KITS

## How much can I save?

The following is an example of the savings you can generate by simply installing an LED retrofit kit in an existing incandescent Exit sign.

<b>The Retrofit Kits Cost is :</b>	\$70.00
Installation cost (per unit) for a retrofit kit is (Labour):	\$5.00
Wattage rating per incandescent lamp in existing fixture:	15W
Number of incandescent lamps per fixture:	2
Wattage rating of Lumacell LMRUNIV retrofit kit:	1.7W
My existing incandescent exit lamps last for:	4 Months
My replacement labour cost is:	\$25.00 / Hour
Estimate lamp replacement time per exit:	20 Minutes
The current material cost for each exit sign lamp is:	\$1.00 / Lamp
My current energy cost is:	\$0.060 / \$ Per kWh
<b>The PAYBACK FOR YOUR INSTALLATION IS:</b>	<b>1.06 Years</b>
<b>THE ANNUAL RETURN ON INVESTMENT IS:</b>	<b>94.50 %</b>
<b>THE ANNUAL SAVING IS:</b>	<b>\$70.87</b>

For more information, please do not hesitate to contact us.

# RSF & RSFSP Series

## Fluorescent inverters

**RSF Series remote inverters and RSFSP Series self-powered inverters.**



### Features

- Converts new or existing fluorescent fixtures into emergency lighting units
- All RSFSP Series are fully load tested prior to shipment
- Inverter is 100% solid state, short and open circuit proof
- Polarized DC input (RSF Series only)
- 120Vac 60Hz input is standard, 277 and 347Vac available as options
- 25%, 50% or 80% lamp lumen output
- Mounts directly in ballast channel, remote or optional T-Bar fixture
- CSA listed



### Typical Specification

**RSF Series:** The electrical contractor shall supply and install Lumacell RSF Series remote fluorescent inverter ballasts for each fixture as shown on plans. The inverter shall operate on \_\_\_\_ Vdc input for \_\_\_\_\_ minutes during a power failure. The fluorescent lamp shall be maintained at \_\_\_\_% lumen output for one lamp only. The inverter is to be connected to the remote battery unit as shown on plans (battery unit to be selected according to voltage/wattage and duration required). The inverter shall be capable of illuminating the fluorescent lamp even when it is burned out under normal AC operation.

**RSFSP Series:** The electrical contractor shall supply and install Lumacell RSFSP Series fluorescent inverters for each fixture as shown on plans. The RSFSP Series inverter shall operate for \_\_\_\_ minutes during a power failure. The fluorescent lamp shall be maintained at \_\_\_\_ % of nominal lumen output. The RSFSP Series inverter shall be capable of illuminating the fluorescent lamp even when it is out under normal AC operations.

Project / Location		Date
Contractor		Prepared by
LUMACELL Model		



# RSF & RSFSP

## Dimensions

### RSF Series

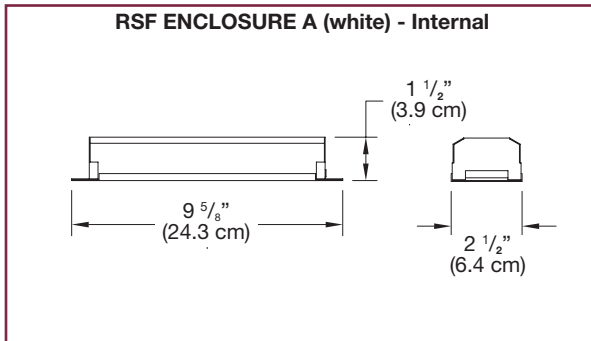

### RSFSP Series

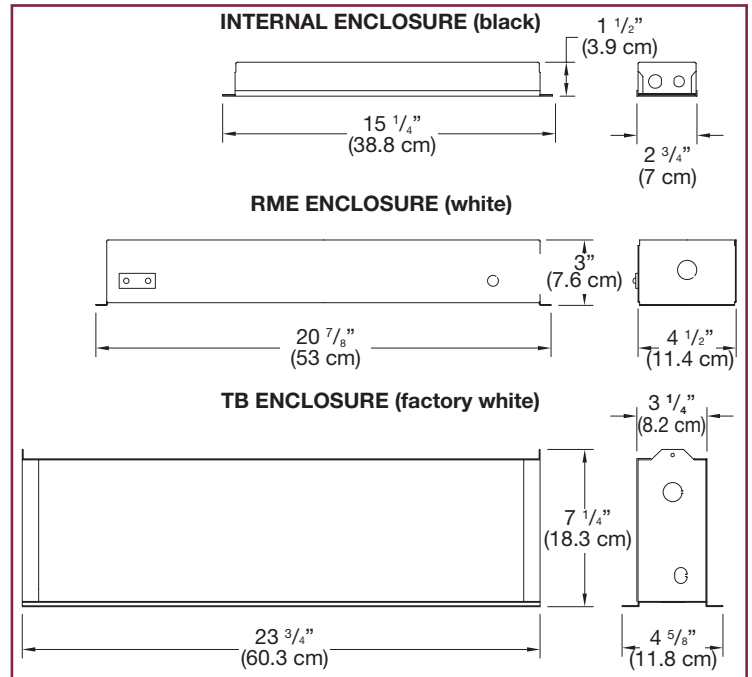

## Ordering Information

### RSF Series

Series	Lumens / % for 48" Tube	A.C. Voltage
<b>RSF</b> = 6Volts	<b>800</b> = 800 lumens (25%)	<b>Blank</b> = 120Vac
<b>RSF12</b> = 12Volts	<b>1600</b> = 1600 lumens (50%)	<b>ZC</b> = 277Vac
<b>RSF24</b> = 24Volts	<b>3200</b> = 2560 lumens (80%)	<b>ZD</b> = 347Vac
<b>RSF32</b> = 32Volts		
<b>RSF48</b> = 48Volts		
<b>RSF120</b> = 120Volts		

### EXAMPLE : RSF800

### RSFSP Series

Series	Lumens/% for 48" Tube	Min. Runtime	Enclosure	A.C. Voltage
<b>RSFSP</b>	<b>800</b> = 800 lumens (25%)	<b>30</b> = 30 minutes	<b>*Blank</b> = internal	<b>Blank</b> = 120Vac
	<b>1600</b> = 1600 lumens (50%)	<b>60</b> = 60 minutes	<b>RME</b> = remote mounting enclosure	<b>ZC</b> = 277Vac
	<b>3200</b> = 2560 lumens (80%)	<b>90</b> = 90 minutes	<b>TB</b> = T-Bar	<b>ZD</b> = 347Vac
		<b>*120</b> = 120 minutes		
	*RSFSP3200 in T-Bar cabinet only.		*Not available for RSFSP3200.	

### EXAMPLE : RSFSP80030

Lumen outputs based on averages.

24"/20W = 1260    48"/40W = 3200    96"/75W = 6300

Inverters will operate T12, T8, or "U" type lamps.

# RSFSP/U/1100 Series

## Fluorescent inverters

Convert fluorescent fixtures into emergency lighting units.



### Features

- Converts new or existing fluorescent fixtures into emergency lighting units
- Each unit is fully computer tested and comes with a 3-year full warranty
- Self-contained in one compact housing for easy installation and maximum mounting flexibility
- Can be wired to operate with switched, unswitched and normally off fixtures without affecting normal operation
- Compatible with standard, energy saving, dimming and electronic AC ballasts
- Maintains operation of one or two lamps when switched to emergency mode
- When AC power is restored, automatically returns the fluorescent lamps to normal operating mode and solid state charger begins recharging the battery
- Sealed maintenance-free nickel cadmium batteries
- CSA listed



### Typical Specification

The contractor will supply and install Lumacell model RSFSP/U/1100 self-powered fluorescent emergency inverter as shown on plans. The fluorescent emergency inverter shall contain a charger, high frequency inverter, and sealed nickel cadmium battery designed for high-temperature operation. The unit shall be able to operate one or two fluorescent lamps and provide not less than

1100 lumens initial light output in emergency mode. The duration of emergency backup shall be at least 90 minutes. Standard input voltage shall be 120V/347Vac 60Hz.

The unit shall be Lumacell Model:  
RSFSP/U/1100 \_\_\_\_\_.

Project / Location		Date
Contractor		Prepared by
LUMACELL Model		



# RSFSP/U/1100

## Dimensions

Catalogue Number	Electrical Input	Dimensions			
		A	B	C	D
<b>RSFSP/U/1100</b>	120/347V 60 Hz 4W	13-3/8" (34.0 cm)	13" (33.0 cm)	2-3/8" (6.0 cm)	1-1/2" (3.8 cm)

## Lamp Operation

RSFSP Series should be used for Octron\* Power Groove\*, VHO and SHO lamps.

\*Octron is a registered trademark of Sylvania. \*Power Groove is a registered trademark of G.E.

Unit Type	Emergency Illumination Time	Lumens	Lamps Able to Operate	Lamps Operated
<b>RSFSP/U/1100</b>	90	1300 *	2	2 to 4 ' (20 to 40 W)**
	90	1300 *	1	2 to 4 ' (20 to 40 W)**

\*Depending on the number of lamps, wattage, and type of lamps selected:  
The RSFSP produces 1100 to 1300 lumens initial emergency light output.  
\*\* Voltage maximum: 40W ( 2 x 20W or 1 x 40W)

## Ordering Information

Series	Option
<b>RSFSP/U/1100</b> = 1100 lumens for 90 minutes 120/347Vac	<b>R</b> = texternal mounting kit

**EXAMPLE : RSFSP/U/1100**

# Wire Guards



## Exit Signs

Part #	Mounting	Signs		Dimensions		
				W	H	D
460.0027-L	Wall Mount	LSR800 Exit LER400 Exit 700 Exit Series 3000 Series - Nema-4X Exit LTEU Exit	LER900 Exit LMCE Exit LER660 Exit LTSU Sortie	10 1/2" (26.7 cm)	6" (15.2 cm)	16" (40.6 cm)
460.0028-L	End Mount	LER800 Exit LER400 Exit 700 Exit Series 3000 Series - Nema-4X Exit LTEU Exit	LER900 Exit LMCE Exit LER660 Exit LTSU Sortie	14 1/2" (36.8 cm)	6 1/4" (15.9 cm)	10 1/2" (26.5 cm)
460.0034-L	Ceiling Mount	RG12S Sortie NH50	RG12S Exit (cab "B")	28 1/4" (7.5 cm)	21 1/8" (53.7 cm)	10" (25.4 cm)
460.0048-L	End Mount	LSR800 Sortie LSR400 Sortie	LSR900 Sortie LSRLMCSU Sortie	10 1/2" (26.7 cm)	6" (15.2 cm)	21" (53.3 cm)
460.0057-L	Wall Mount	LSR800 Sortie LSR400 Sortie	LSR900 Sortie LSRLMCSU Sortie	21" (53.3 cm)	10" (25.4 cm)	4" (10.2cm)
460.0058-L	Ceiling Mount	LSR800 Sortie LSR400 Sortie	LSR900 Sortie LSRLMCSU Sortie	21 3/4" (55.2 cm)	5 1/2" (14 cm)	10 1/2" (26.7cm)
460.0059-L	Wall Mount	900B6L bilingual Series LMCSB6L Sortie	400B6L bilingual Series LMCEB6L Exit	34" (86.4 cm)	10" (25.4 cm)	5 1/2" (14 cm)
460.0060-L	End Mount	3LSRLMCSU series Sortie Combo 3000 Series-Nema-4X Exit Combo	8LMCSU Sortie Combo	20" (50.8 cm)	12" (30.5 cm)	15" (38.1 cm)
460.0060-L	Wall Mount	3LSR400 Sortie Combo	3LER400 Exit Combo	20" (50.8 cm)	12" (30.5 cm)	15" (38.1 cm)
460.0060-L	Ceiling Mount	3000 Series-Nema-4X Exit Combo		20" (50.8 cm)	12" (30.5 cm)	15" (38.1 cm)
460.0078-L	Wall Mount	3LSRLMCSU Sortie Combo 3000 Series-Nema-4X Exit Combo 3LSR400 Sortie Combo	8LMCSU Exit Combo 3LER400 Exit Combo	18" (45.7 cm)	18" (45.7 cm)	7" (17.8 cm)
460.0079-L	Wall Mount	LER800 Exit LER400 Exit 700 Exit Series 3000 Series-Nema-4X Exit LTEU Exit	LER900 Exit LMCE Exit LER660 Exit LTSU Sortie	14" (36.6 cm)	10" (25.4 cm)	4 1/2" (11.4 cm)
460.0080-L	Wall Mount	LER-HZ combo (class1 Div2)	LER-HZ Exit	15 1/4" (38.7 cm)	14 1/8" (35.9 cm)	6 1/2" (16.5 cm)
460.0081-L	Wall Mount	RG12S Exit (cab "A")		20" (50.8 cm)	17 1/8" (43.6 cm)	8 1/2" (21.6 cm)
460.0091-L	Wall Mount	LER400R Exit Series		15" (38.1 cm)	10 1/2" (26.7 cm)	1" (2.5 cm)
460.0092-L	Ceiling Mount	3LSRLMCSU Sortie Combo Series	8LMCSU Sortie Combo	31" (53.3 cm)	4.5" (11.4 cm)	10" (25.4 cm)

Project / Location		Date
Contractor		Prepared by
LUMACELL Model		

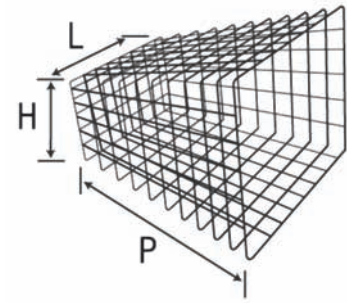

# WIRE GUARDS & MOUNTING SHELVES

## Battery Units

Part #	Mounting	Commercial, Deco Unit	Dimensions		
			W	H	D
460.0078-L	Wall Mount	"A" Cabinet - 6V, 12V, 24V - Max. 144watts	17" (43.2 cm)	17" (43.2 cm)	7" (17.8 cm)
460.0081-L	Wall Mount	"B" Cabinet - 6V - 180watts 12V - 200 to 360watts 24V - 200 to 288watts	20" (50.8 cm)	17 1/8" (43.6 cm)	8 1/2" (21.6 cm)
460.0034-L	Wall Mount	"C" Cabinet - 12V - 650watts 24V - 350 to 720watts	28 1/8" (71.5 cm)	21 1/8" (53.7 cm)	10" (25.4 cm)
	Wall Mount	"D" Cabinet - 12V - 360watts HP, 900watts 24V - 720watts HP			

### Small, 6Volt

460.0080-L	Wall Mount	6V, 12V - 18 to 72watts	15 1/4" (38.7 cm)	14 1/8" (35.9 cm)	6 1/2" (16.5 cm)
------------	------------	-------------------------	-------------------	-------------------	------------------

### Industrial W4T

460.0082-L	Wall Mount	Small Cabinet	12" (30.5 cm)	9" (3.5 cm)	9" (3.5 cm)
460.0081-L	Wall Mount	Medium and Large Cabinet	20" (50.8 cm)	17 1/8" (43.6 cm)	8 1/2" (21.6 cm)

## Remote Heads

Part #	Remote Heads	Dimensions		
		W	H	D
460.0029-L	MT1, MT2, DR1130, DR2130, MQ, MQM	6 1/4" (15.9cm)	8 1/4"(21.0cm)	6 3/4"(17.2cm)
460.0031-L	RSQBD, RG-NX	28"(71.1cm)	8 1/2"(21.5cm)	8 1/2"(21.5cm)
460.0032-L	RSQB2	9 1/2"(24.1cm)	9 1/2"(24.1cm)	6 1/8"(15.6cm)
460.0033-L	RS22, RS34	9 1/2"(24.1cm)	9 1/2"(24.1cm)	4"(10.2cm)
460.0035-L	RS10, RS10WP, RS10WPRB, RSQB, MQM-NX, MQM-NC, RS40 MQM-HZ	8 7/16"(21.5cm)	6"(15.2cm)	8 7/16"(21.5cm)
460.0082-L	RS20, RS20WP, RS20WPRB, SAF-T-RAY, CAMRAY	12"(30.5cm)	9"(22.9cm)	9"(22.9cm)
460.0100-L	DIVIDER®	14"(35.6cm)	5.8"(14.7cm)	5.6"(14.2cm)

## Mounting Shelves

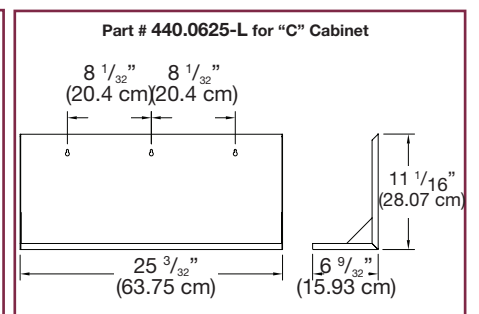
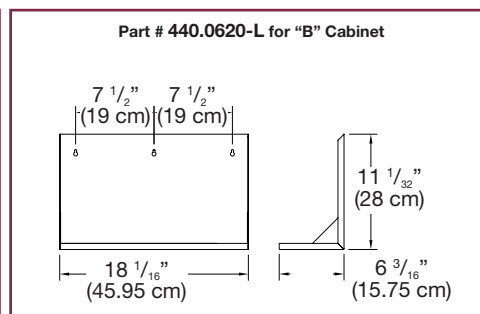
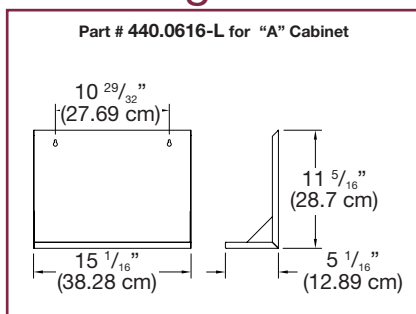

# NEXUS® System

## Network Management System

**NEXUS®** is a real-time emergency lighting monitoring and control system which offers building owners/managers control over their public safety obligations, and helps manage installation and the maintenance of an emergency lighting system. A Nexus network enables the user to -

- Manage the installation and removal of components
- Cost effectively test and monitor the system
- Assign fittings to groups
- Manage maintenance activities
- Ensure tests are preformed properly
- Prepare reports
- Log test results and print as required

### Advantages of NEXUS®

**Labor Saving** – Nexus® enables the user to remotely activate emergency lighting units and retrieve status information.

This information is then automatically stored in an electronic log book. Maintenance personnel need only attend to units that require maintenance.

**Maximize System Availability** – Nexus® can test and report on the status of an entire emergency lighting system within a building individually, in groups or all together.

**Self Monitoring** – Nexus® is self-monitoring. In an event of cable damage, Nexus® can indicate the location of the fault down to the particular branch, which could potentially save hours of manual fault finding

**Independent System** – The operation of emergency lighting is not impeded by nor dependant upon Nexus®. A Nexus light fitting can be removed from or added anywhere within the Nexus network without interruption to the operation of the system.

**Data Integrity** – Nexus®s can minimize human errors which affect the validity of data, by automating processes and logging maintenance data.

**Bus Topology** – Nexus® fittings are connected by a twisted pair data cable in a double terminated multi-drop bus topology.

**Single Twisted Pair Cable** – The Nexus® system requires a single shielded twisted pair cable as the network medium. The cable offers high communication speed and high resistance to external interference.

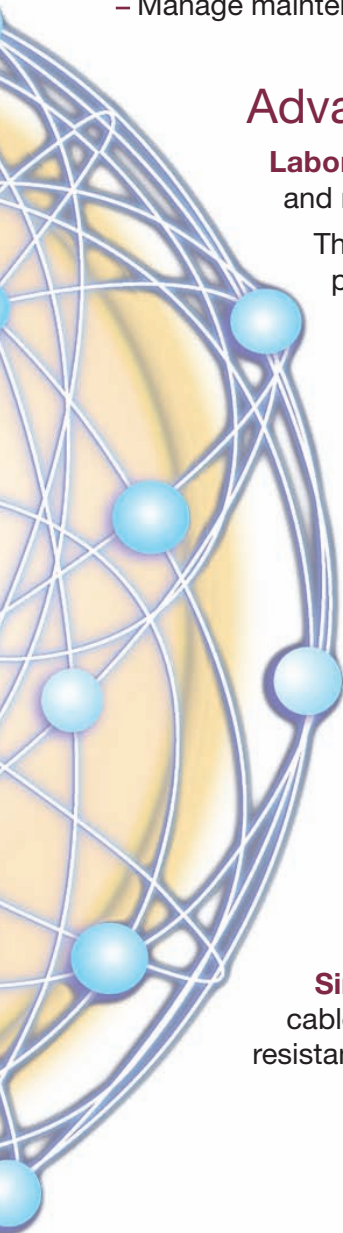

# NEXUS

Easy to use Graphic User Interface – The **Nexus**<sup>®</sup> software contains an easy to use graphic user interface which guides the user through a series of functions

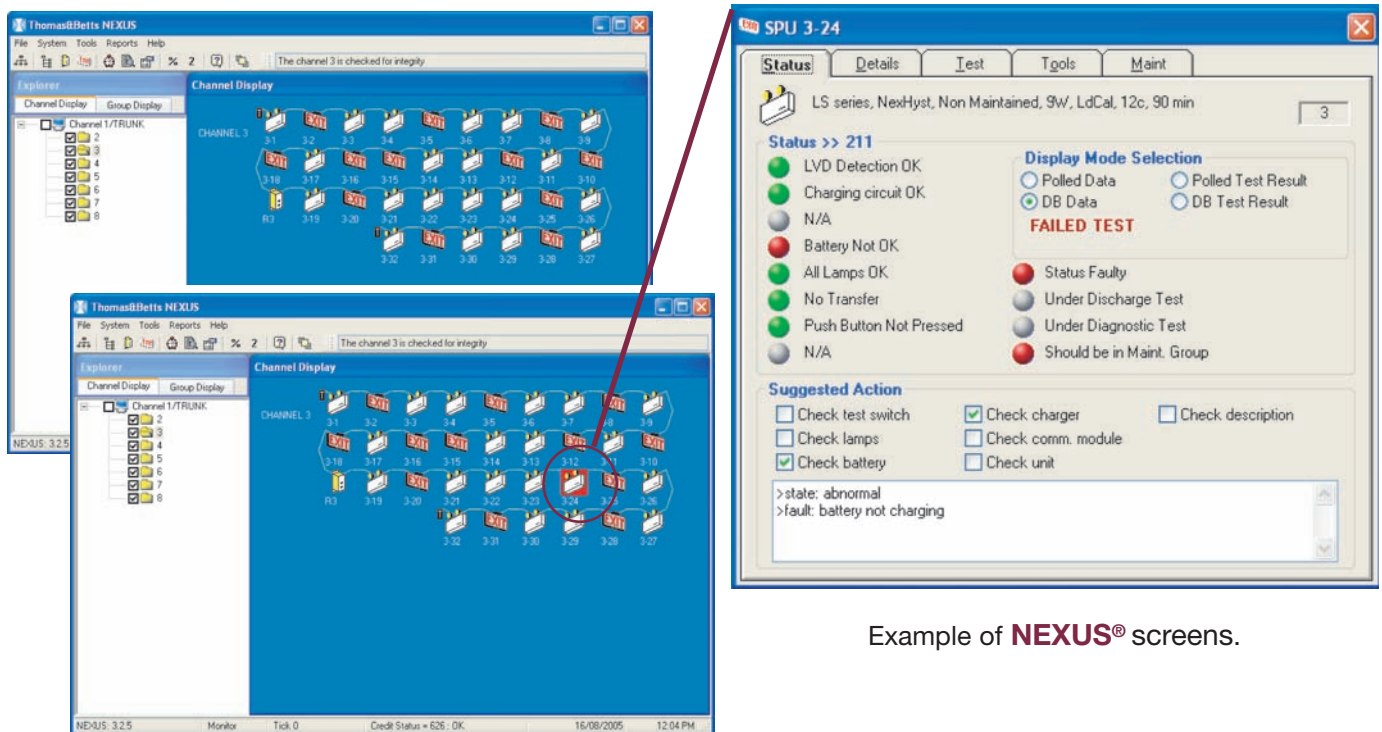

Example of **NEXUS**<sup>®</sup> screens.

**Nexus**<sup>®</sup> Warranty – Lumacell emergency lighting equipment units with the **Nexus**<sup>®</sup> options are fully warranted to be free of defects in material and workmanship under normal use for a period of five (5) years. The full warranty period begins on the date of installation or ninety (90) days from the date of shipment, whichever date is earlier.

Wherever you are, you can depend on  
NEXUS to get the job done!

For more information please contact us at:  
**1-866-857-5711 (ext. 7515)**  
**nexus-info@tnb.com**





