

Remote heads in a few words...



EMERGENCY LIGHTING HEADS: PERFORMANCE & TECHNOLOGY

Emergency Lighting Heads represent a key element of an emergency lighting system performance. During a power failure, these lamp heads must provide adequate lighting levels for the safe evacuation of humans from buildings.

Which level of illumination is necessary to ensure a safe evacuation? Minimum levels are established by the National Building Code of Canada:

“3.2.7.3. Emergency Lighting

- 1- Emergency lighting shall be provided to an average level of illumination not less than 10 lx at floor or tread level
- 2- Emergency lighting to provide an average level of illumination of not less than 10 lx at floor or catwalk level shall be included in a service space referred to in Sentence 3.2.1.1.7).
- 3- The minimum value of the illumination required by Sentences (1) and (2) shall not be less than 1 lx.”

During a power failure, the emergency power supply is provided to the heads from batteries. Equipment manufacturers and customers should use high intensity light sources, with efficient light levels and distributions. Let's examine which light sources are used for emergency lighting and which are the best ones?

MINIATURE LAMPS: TUNGSTEN AND QUARTZ HALOGEN

Most commonly used emergency heads are fabricated of an injection-molded thermoplastic housing containing a miniature lamp, a metallic reflector and a polycarbonate lens. Lamps use a tungsten filament enclosed in a filling gas mixture of argon and nitrogen and are generally referred to as incandescent lamps.

A better performance is obtained with quartz halogen lamps, which are still incandescent lamps, but the filling gas (iodide/chloride) allows the tungsten filament to operate at higher temperatures. This results in higher luminous intensity, 20 to 30% superior to standard incandescent lamps of same wattage and lamp life.

Table 1 shows a comparison between miniature incandescent lamps and quartz halogen lamps. The luminous intensity is measured in MSCP (mean spherical candle power).

Remote heads in a few words...



TABLE 1

Lamp Type	Application	Voltage (V)	Wattage (W)	Average Life (hrs)	Luminous Intensity (MSCP)	Relative Luminous Intensity
INCANDESCENT	Emergency Lighting	6	12	50	15	100%
HALOGEN	Emergency Lighting	6	12	50	19	127%

You have probably already noticed the short lamp life of these light sources. Who would be interested in using a bulb which only lasts 50 hours? The answer is simple: such a lamp produces 25% to 30% more light than a lamp of the same wattage but longer lamp life (ie. 1,000 hours).

By design, the filament is used at higher temperatures, increasing light output.

However, using high temperatures also increases vaporization of the filament, which in turns shortens its life. As power failures are relatively scarce (let's say 4 to 6 per year) and duration of emergency lighting between 30 minutes to 2 hours, lamp heads are only used between 3 to 12 hours per year. A lamp with an average life of 50 hours should therefore be functional during over four years.

Lamp manufacturers offer two types of miniature lamps : long life and high light output.

Table 2 shows a few examples.

TABLE 2

Lamp Type	Application	Voltage (V)	Wattage (W)	Average Life (hrs)	Luminous Intensity (MSCP)	Relative Luminous Intensity
INCANDESCENT	Specialty	12	8	1 000	10	100%
	Emergency Lighting	12	8	50	13	130%
	Emergency Lighting	6	8	50	13	130%
HALOGEN	Automobile, Rough Service,	12,8	12,8	1 000	12	100%
	Emergency Lighting	6	12	50	15	120%



PAR36 SEALED BEAM LAMPS

Emergency head performance also depends on lamp optics: the reflector and the lens. This is especially critical in damp areas where vapors and water condensation can deteriorate the electrical contacts and the reflector performance.

Sealed beam lamps are recommended for such applications.

Sealed beam lamp construction includes a metal coated glass reflector and a lens, designed to provide a light beam of a certain opening: narrow, medium, large, etc. The most common lamps used are those with a 4.5" diameter (PAR36), available in both incandescent and halogen versions. As for miniature lamps, there are sealed beam lamps dedicated for long life applications (4,000 hours, 7-8 lumens/Watt) and for emergency lighting (50 to 300 hours, 12-20 lumens/Watt).

Originally, lamp life wasn't an issue. However, this has become increasingly important in recent years, with the introduction of sophisticated emergency lighting fixtures with periodic self-test and self-diagnostic features.

Such a system includes a micro-controller board which automatically simulates a power failure and forces the fixture in emergency lighting mode every 30 days for at least 30 seconds and tests both the batteries and the lamps. Even if the duration of the self-test is minimal compared to the lamp life, the repetitive connection and disconnection cycle of the lamps increases the risk of a premature failure caused by the initial high current applied.

MR16 GENERATION

Fortunately, the lamp life issue was resolved with a new generation of lamps: the MR16 technology (MR16 stands for Multi-faceted Reflector, 16/8" diameter). Increasingly popular, the MR16 contains everything in one: miniature halogen lamp, metal coated glass reflector and, for the most part, a glass lens cemented to the reflector. Easy to install, MR16 lamps are popular in both residential and commercial applications, and increasingly specified for emergency lighting. Why?

In addition to their bright directional beam, these lamps offer a good efficacy (11 to 18 lumens/Watt), as well as long life (2,000 to 6,000 hrs). How is this possible?

First, the use of a glass lens which is clear and thin, absorbing much less light than standard diffuser lens, and second: an efficient light distribution, accomplished by the multi-faceted reflector.

Table of contents



CAMRAY Series p 166 - 167



- Illuminating the dark, decorating the day.

MQM*NC Series p 168 - 169



- Shielded Remote Fixture.

SAF-T-RAY Series p 170 - 171



- Wall mount remote head.

PHANTOM Series p 172 - 173



- The unseen solution,
an architect's dream

MINI-PHANTOM Series p 174 - 175



- Recessed cabinet emergency
lighting system.

DIVIDER® Series p 176



- Compact remote emergency lighting fixture.

RS22 Series p 177



- Remote emergency lighting fixture.

MT / MQ / MQM Series p 178 - 179



- Micro-tungsten lamps,
micro quartz lamps, MR16 lamps.

RS10 / RS20 / RS30T Series p 180 - 181



- Surface mounted remote emergency
lighting fixture.

RSQB / RSQBD / RSQB2 Series p 182 - 183



- Cubic surface mounted remote fixture.

SIGNATURE Collection p 184



- Surface designer series.

MQM*NX Series p 190 - 191



- NEMA-4X and NSF certified remote fixture.

WP Series p 185



- Weatherproof MR16 powder coated cast aluminum light head

RS10XP Series p 192 - 193



- Explosion proof remote lighting fixture.

RSTH SIGNATURE p 186 - 187
Remote Collection



- Recessed designer series.

MQM*HZ Series p 194 -195



- Hazardous Class I Div 2 remote fixture.

RS*WP Series p 188



- Weatherproof remote emergency lighting fixture.

Lamp Chart p 196 - 199



- Lamp and head chart

RS*WPRB Series p 189



- Weatherproof remote emergency lighting fixture.

Glossary p 200

- Codes Description

CAMRAY Remote Fixture

Illuminating the dark, decorating the day



Features

- Suitable for wet and cold locations. (-40°C à +60°C)
- Premium quality die cast body.
- Xenon lamps with patent pending vacuum metallized die cast reflector.
- Suitable for indoor and outdoor applications.
- Fast and easy installation.
- Fully gasketed housing.
- CSA certified to C22.2 N°50.



Typical Specification

Supply and install Lumacell Camray remote head. The remote head shall include two lamps of ___ Watts. The fixture shall be made of a fully gasketed die cast aluminum housing, a UV stabilized and shock resistant polycarbonate lens, and a rugged vacuum metallized die cast reflector containing two Xenon

lamps. The fixture shall be suited for universal mounting on a variety of junction boxes. The remote unit shall be certified to CSA standard C22.2 N°. 50.

The remote head shall be Lumacell model:
CAM_____

In the same family...



CAMRAY

Battery Units p. 110 - 111

Project / Location		Date
Contractor		Prepared by
LUMACELL Model		



CAMRAY

Wire Guard

460.0082-L	Wall Mount
------------	------------

Dimensions

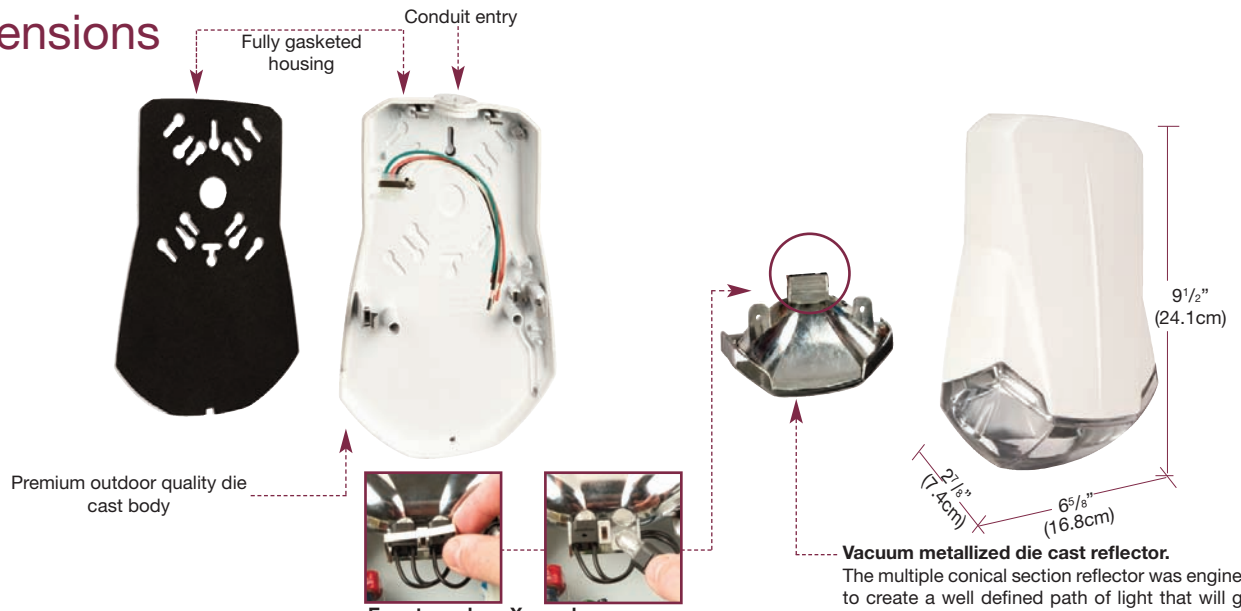

Easy to replace Xenon lamps.
Unlike quartz bipin, Xenon lamps can be easily installed using your fingers.

Vacuum metallized die cast reflector.
The multiple conical section reflector was engineered to create a well defined path of light that will guide occupants to safety in case of an emergency.

Replacement Lamps

Model	Lamp Type	Voltage-Wattage
570.0213-L	Xenon, wedge base	6V-6W
570.0214-L	Xenon, wedge base	6V-10W

See the complete list p. 196 to 199.

Ordering Information

Series	Lamp Wattage	Colour	Options
CAM = remote fixture -40°C to +60°C (-40°F to +140°F)	6V6W	OW = off white	6 = 6V
	6V10W	BK = black	12 = 12V
	12V6W	DB = dark bronze	
	12V10W	PG = platinum grey	
	Xenon lamps	Other colours available. consult your sales representative	

EXAMPLE: CAM6V6WOW6

MQM-NC Series Remote Fixture

Shielded remote fixture



Features

- Quality illumination requires fewer fixtures.
- Modern design will blend into surroundings.
- Shielded to prevent tampering.
- Easy installation.
- Available in 6V, 12V, 24V or 120V.
- CSA certified to C22.2 N°50.



Typical Specification

Supply and install Lumacell MQM-NC series remote emergency lighting. These remote fixtures will consist of either single or double lamp configurations according to the design and include a die cast aluminum back plate and a clear heavy-duty UV resistant polycarbonate light cover.

The remote fixture shall be certified to CSA C22.2 N°50.

The head(s) shall be fully adjustable and be equipped with high efficiency MR16 halogen lamp(s) of _____ volts, _____ watts.

The remote unit shall be Lumacell model: MQM _____.

In the same family...



RGA

Battery Units p. 120 - 121



MQM-NX NEMA-4X

Remote Fixtures p. 190 - 191



MQM-HZ Class I, Div. 2

Remote Fixtures p. 194 - 195

Project / Location		Date
Contractor		Prepared by
LUMACELL Model		



MQM-NC

Dimensions

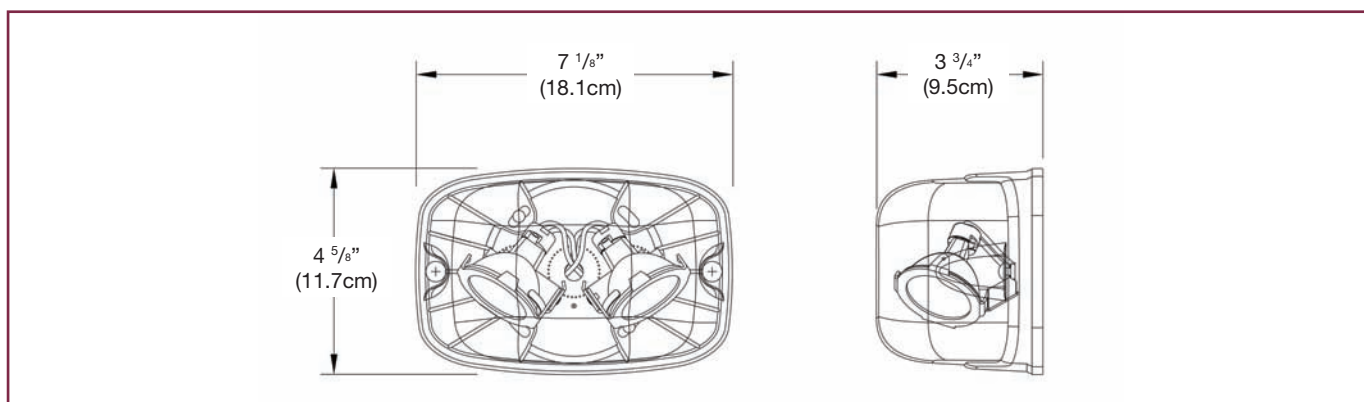

Replacement Lamps

Model	Lamp Type	Voltage-Wattage
580.0079-L	MR16 Flood	6V-10W
580.0080-L	MR16 Flood	12V-12W
580.0077-L	MR16 Flood	24V-20W

See the complete list p. 196 to 199.

Ordering Information

Series	Voltage/Wattage/Lamp	Colour	Options
MQM1NC = one lamp	6V6W = 6V-6W, MR16	Blank = factory white	Blank = no options
MQM2NC = two lamps	6V10W = 6V-10W, MR16	BK = black	TP = tamper proof screws
	12V12W = 12V-12W, MR16	SG = grey	*690.0454-L = tamper proof bit
	12V20WH = 12V-20W, MR16, high output		
	24V12W = 24V-12W, MR16		
	24V20W = 24V-20W, MR16		
	120V20W = 120V-20W, GU10		
	L = 12V-5W, LED		
		* Other colours available. consult your sales representative	*One bit needed per order (must be ordered separately)

EXAMPLE: MQM1NC6V6W

SAF-T-RAY Series

Wall mount remote head



Features

- Compact wall sconce unit for indoor and outdoor use
- High impact resistant polycarbonate diffuser
- Die-cast aluminum housing
- For outdoor and indoor use
- Adjustable lamps
- Vandal resistant option
- CSA Certified to C22.2 N° 50



Typical Specification

Wall mount unit shall be gasketed die-cast aluminum housing, impact resistant polycarbonate diffuser. The lamps shall be in adjustable for aisle or area distribution.

Fixture shall be supplied with gasket and shall be suitable for installation on any four inch octagonal box.

The remote unit shall be Lumacell model:
SAF_____

Project / Location		Date
Contractor		Prepared by
LUMACELL Model		



SAF-T-RAY

Dimensions

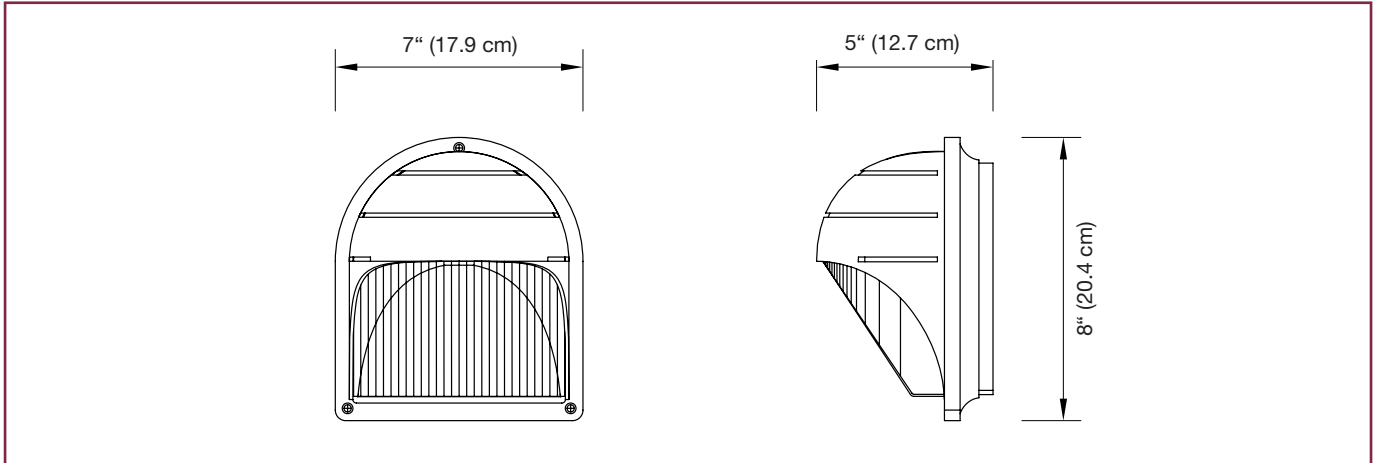

Replacement Lamps

Model	Lamp Type	Voltage-Wattage
580.0079-L	MR16 Flood	6V-10W
580.0080-L	MR16 Flood	12V-12W
580.0068-L	MR16 Flood	12V-20W
580.0077-L	MR16 Flood	24V-12W
580.0070-L	MR16 Flood	24V-20W

See the complete list p. 196 to 199.

Ordering Information

Series	Lamp Type	Voltage/Wattage	Colour	Options
SAF= exterior remote	Blank= (1) med. base socket only (max. 60W), no lamp included, for non-emergency M= MR16	Blank= no lamp	Vide= factory white	Blank= no options
		6V10W= (2) MR16 6V-10W	BK= black	VR= vandal resistant screws
		12V12W= (2) MR16 12V-12W	DG= dark grey	
		12V20WH= (2) MR16 12V-20W high output	DB= dark bronze	
		24V12W= (2) MR16 24V-12W		
		24V20W= (2) MR16 24V-20W		

EXAMPLE: SAF

PHANTOM Series Remote Fixture

The unseen solution, an architect's dream



Features

- Fully automatic operation: the unit door opens upon supply with DC voltage from battery and closes after the voltage disconnect
- DC input: 12Vdc or 24Vdc;
- AC line voltage is NOT required
- Emergency lights: two high-efficacy MR16 halogen lamps; power range: 2x12 ... 2x50 Watts
- Installation: finished dry-wall or un-insulated ceiling (after the dry-wall put-in)
- Accessories: include electrical junction box and "U"-shape bracket for concealed installation
- Options: hardware kit for T-Bar mounting; high-lumen output lamps (20, 35 and 50W)
- Warranty: five-year limited warranty
- Certification: CSA C22.2 N° 50



Typical Specification

Supply and install Lumacell Phantom Series of remote fixture: The unit shall be designed to be concealed in walls or ceilings with a cavity. The unit equipment shall be completely concealed in the wall or ceiling in the absence of remote power. Upon DC power supply the unit will rotate its door by 180° to expose the emergency lamps and then will power them. After the DC power disconnect the lamps will turn off and the unit will conceal the heads in the wall (ceiling) by rotating the door by 180°. The DC-remote unit shall not require the presence of AC power in order to open or close the door.

Under normal conditions, the only visible parts of the unit shall be the off-white flat door and trim plate, that can be customized on site with paint or other suitable wall covering. The light source shall be 12V MR16 halogen lamps of specified wattage and light output.

The remote unit shall be the Lumacell model:
PHAR _____ .

In the same family...



PHANTOM™

Battery Units p. 114 - 115

Project / Location		Date
Contractor	Prepared by	
LUMACELL Model		



PHANTOM

Dimensions

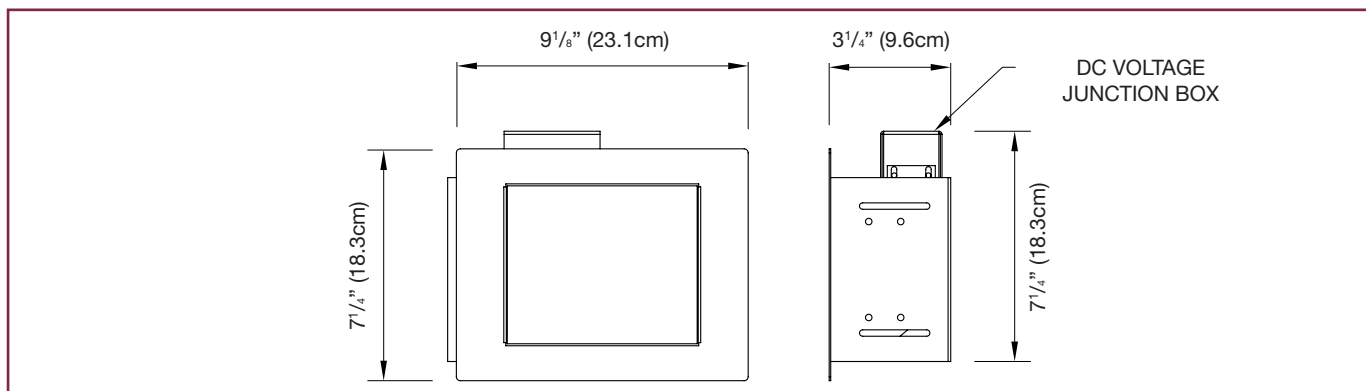

The opening of the wall/ceiling mounted remote head is 5 3/4" (14.6cm) x 8" (20.3cm).
Dimensions are approximate and subject to modifications.

Replacement Lamps

Model	Lamp Type	Voltage-Wattage
580.0080-L	MR16 12W Flood	12V-12W
580.0064-L	MR16 20W Flood	12V-20W
580.0083-L	MR16 35W Flood	12V-35W
580.0076-L	MR16 50W Flood	12V-50W
580.0068-L	MR16 IR* 20W Flood	12V-20W
580.0090-L	MR16 IR* 35W Flood	12V-35W
580.0089-L	MR16 IR* 50W Flood	12V-50W
580.0084-L	MR16	24V-35W
580.0070-L	MR16	24V-12W
580.0077-L	MR16	24V-20W
580.0078-L	MR16	24V-50W

* High-output (H).

See the complete list p. 196 to 199.

Ordering Information

Series	Remote Voltage	Lamp Wattage (MR16)	Options
PHAR = remote fixture	12V = 12Vdc 24V = 24Vdc	12W = 12 watts, MR16	TB = T-Bar mounting kit
		20W = 20 watts, MR16	
		35W = 35 watts, MR16	
		50W = 50 watts, MR16	
		20WH = 20 watts, MR16 high output	
		35WH = 35 watts, MR16 high output	
		50WH = 50 watts, MR16 high output	

EXAMPLE: PHAR12V12WTB

MINI-PHANTOM Remote Fixture

For AC power generator



Features

- Easy to retrofit in finished walls: the unit slides in through an 8.25-in by 5.75-in hole
- No back-box needed to pre-install
- Fully automatic operation: the unit door opens upon supply with AC power and closes at the end of power back-up
- Output: 12Vac with up to 100 watts of power
- Direct connection to 120 or 347Vac power generators
- Emergency lights: MR16 halogen lamps; power range from 12 to 50 Watts
- Certification: CSA C22.2 N°50



Made in Canada



Typical Specification

Supply and install Lumacell Series Mini-Phantom. The unit shall be designed to be completely concealed in walls with a cavity. The equipment shall consist of a metal housing containing two modules joined by a flexible bracket and electric conduit. One module contains the power transformer and electrical connection box; the other module contains the emergency lights installed on the back of a door able to rotate several turns of 360°. The unit equipment shall be completely concealed in the wall, after the installation through a rectangular opening not larger than 8.25-in by 5.75-in.

In stand-by mode, the only visible parts of the unit shall be the off-white flat door and trim plate that can be customized on site with paint or other suitable wall

covering. Upon AC power supply the unit will expose the emergency heads by rotating its door 180° and then will power the lamps. At the end of the AC power, the lamps will turn off and the unit will retract the heads by rotating the door 180° in the same direction.

The unit shall not require the presence of AC power in order to close the door and conceal the lights. The door of the unit shall be easy to force-turn (open or close) by hand. The light source shall be 12V MR16 halogen lamps of specified wattage and light output.

The remote unit shall be the Lumacell model:
MPG _____.

In the same family...



MINI-PHANTOM

Battery Units p. 116 - 117

Project / Location		Date
Contractor		Prepared by
LUMACELL Model		



MINI-PHANTOM

Dimensions

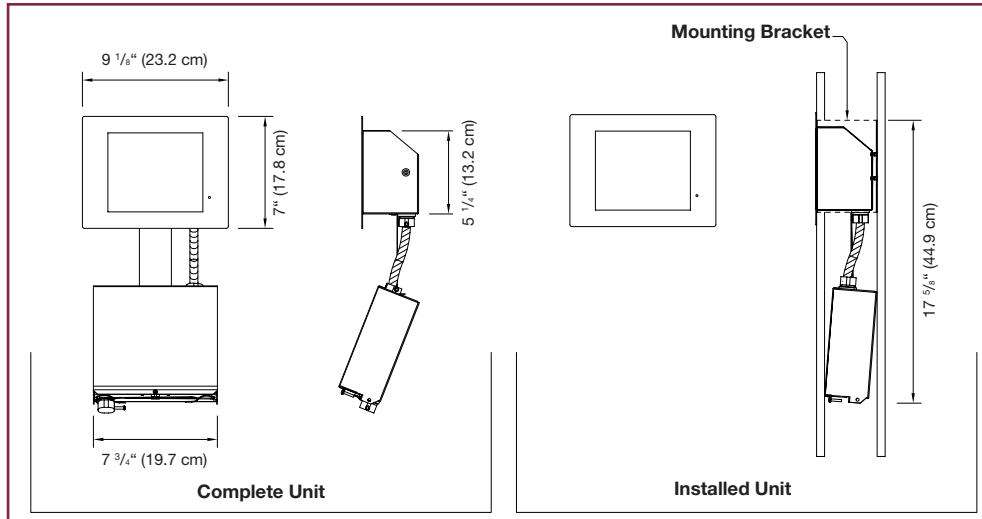

Replacement Lamps

Model	Lamp Type	Voltage-Wattage
580.0080-L	MR16 12W Flood	12V-12W
580.0064-L	MR16 20W Flood	12V-20W
580.0083-L	MR16 35W Flood	12V-35W
580.0076-L	MR16 50W Flood	12V-50W
580.0068-L	MR16 IR * 20W Flood	12V-20W
580.0090-L	MR16 IR * 35W Flood	12V-35W
580.0089-L	MR16 IR * 50W Flood	12V-50W

* High-output (H).

See the complete list p. 196 to 199.

Ordering Information

Series	Unit Capacity	Lamp Wattage	AC Voltage
MP	G = Remote AC generator, max. 100W	12W = 2x 12 watts MR16	Blank = 120Vac
		20W = 2x 20 watts MR16	ZC = 277Vac
		35W = 2x 35 watts MR16	ZD = 347Vac
		50W = 2x 50 watts MR16	
		20WH = 2x 20 watts MR16, High output	
		35WH = 2x 35 watts MR16, High output	
		50WH = 2x 50 watts MR16, High output	

EXAMPLE: MPG35WH

DIVIDER® Series Remote Fixture

Compact emergency lighting

RS22 Series

Recessed Mounted series



DIVIDER®



Dimensions

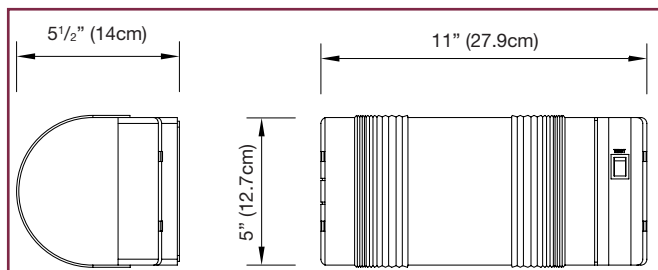

Features

- Injection molded, impact-, scratch- and corrosion-resistant thermoplastic housing.
- Compact unit measures only 11" x 5", wall or ceiling mount.
- Available with tungsten lamps, 9 Watts, 6V, 12V, or 24V.
- Certification: CSA C22.2 N°.50

Wire Guard

460.0100-L	Wall Mount
------------	------------

Replacement Lamps

Model	Lamp Type	Voltage-Wattage
570.0016-L	Mini tungsten, wedge base	6V-9W
570.0025-L	Mini tungsten, wedge base	12V-9W
570.0045-L	Mini tungsten, wedge base	24V-9W

See the complete list p. 196 to 199.

Ordering Information

Series	Voltage/Wattage/Lamp Type	Colour	Options
R-DIVIDER = remote fixture	6V9W = 6V-9W, tungsten, wedge base	Blank = factory white	Blank = no options
	12V9W = 12V-9W, tungsten, wedge base	BK = black	VR = vandal resistant screws
	24V9W = 12V-9W, tungsten, wedge base		*990.0119-L = tamper proof bit
			* One bit needed per order.

EXAMPLE: R-DIVIDER6V9W

In the same family...



DIVIDER®

Battery Units p. 118 - 119

Project / Location		Date
Contractor		Prepared by
LUMACELL Model		



DIVIDER® / RS22

RS22



Dimensions

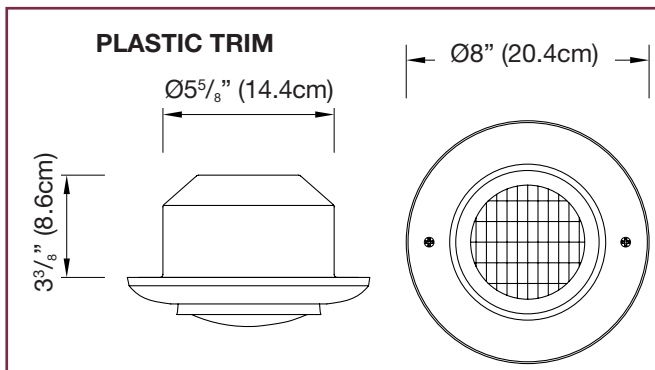

Features

- PAR 36, recess mounted fixtures with gimbal ring
- Durable thermoplastic trim ring standard; metal trim available as an option
- Gimbal ring adjustable on two planes to 45°
- No extra housing needed
- CSA certified to C22.2 N°50.

Replacement Lamps

Model	Lamp Type	Voltage-Wattage
570.0016-L	Tungsten	6V-9W
570.0025-L	Tungsten	12V-9W
570.0045-L	Tungsten	24V-9W

See the complete list p. 196 to 199.

Wire Guard

460.0033-L	Wall Mount
------------	------------

Ordering Information

Series	Voltage/Wattage/Lamp Type	Colour	Options
RS22= par 36 recessed with plastic trim	6V9W = 6V-9W, tungsten, wedge base	Blank = factory white	Blank = no options
	6V_W = 6V-18 or 25W, tungsten, DCB		
	12V_W = 12V-9 ou 18W, tungstène, wedge base	BK = black	M = metal trim LBB = les backbox
	12V25W = 12V-25W, tungsten, DCB		
	24 V_W = 24V-9 or 18W, tungsten, wedge base		
	Q6V_W = 6V-8, 12 or 20W, halogen, quartz bi-pin		
	Q12V_W = 12V-8, 12, 20 or *55W, halogen, quartz bi-pin		
	Q24V_W = 24V-20 or *70W, halogen, quartz bi-pin		
	SB12V_W = 12 V-12, 18 or 25W, tungsten, sealed beam		
	32V_W = 32V-18 or 25W, tungsten, DCB		
	120V_W = 120V-10, 15W, tungsten, DCB		
	Q120V35W = 120V-35W, halogen, DCB		
	Q120V50W = 120V-50W, halogen, DCB*		
* Available with metal trim only. NOTE : " _ " insert wattage required Other types available, consult your sales representative			

EXAMPLE: RS226V9W

MT / MQ / MQM Series Remote fixtures

micro tungsten lamps, micro-quartz lamps
or MR16 lamps



Features

- Compact design
- 6, 12 and 24 volts with various wattages
- Variable light patterns using adjustable lens
- Fire-retardant thermoplastic
- Available with tungsten, quartz lamps or MR16
- 300° rotation
- CSA certified to C22.2 N°50.



Typical Specification

Lamp head and stem shall be injection molded, impact resistant, flame retardant thermoplastic and shall require no tool for aiming or adjustment. The lens shall be inverse concave design and fully adjustable for aisle or area distribution during installation without the need to energize the lamp. Visual identification of distribution shall be provided through position of adjustment pins.

Fixture shall be supplied with a canopy for installation on any four inch octagon box. Housing shall be so designed to allow for lamp replacement if required.

The remote unit shall be the Lumacell model:
M_____ .

Project / Location		Date
Contractor		Prepared by
LUMACELL Model		



Wire Guard

460.0029-L	Wall Mount
------------	------------

MT / MQ / MQM

Dimensions

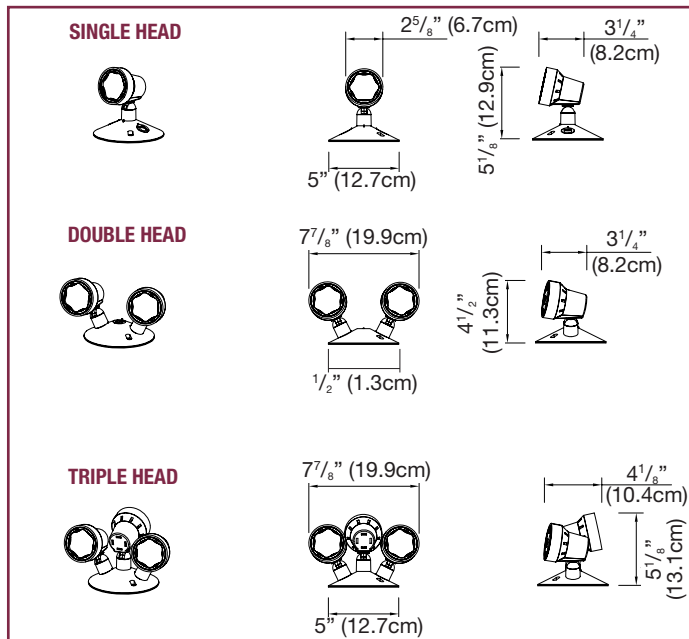

Replacement Lamps

Model	Lamp Type	Voltage-Wattage
570.0016-L	Tungsten	6V-9W
570.0045-L	Tungsten	24V-9W
570.0015-L	Halogen (quartz)	12V-12W

See the complete list p. 196 to 199.

Ordering Information

Series	Lamp Type	# of Heads	Voltage/Wattage/Lamp Type	Colour
M = micro, PAR 18	T = tungsten, wedge base	1 = single head	6V9W = 6V-9W, wedge base	Blank = factory white
	Q = halogen, quartz bi-pin	2 = double head	12V9W = 12V-9W, wedge base	BK = black
	QM = halogen, MR16	3 = triple head	12V18W = 12V-18W, wedge base	
			24V9W = 24V-9W, wedge base	
			24V18W = 24V-18W, wedge base	
			6V8W = 6V-8W, quartz bi-pin	
			6V12W = 6V-12W, quartz bi-pin	
			12V8W = 12V-8W, quartz bi-pin	
			12V12W = 12V-12W, quartz bi-pin	
			6V6W = 6V-6W, MR16	
			6V10W = 6V-10W, MR16	
			12V12W = 12V-12W, MR16	
		12V20W = 12V-20W, MR16		
		24V12W = 24V-12W, MR16		

EXAMPLE: MT16V9W

RS / RS20 / RS30T Remote Fixtures

Surface Mounted Series



Features

- PAR36, surface-mounted, large remote fixtures
- Single, double or triple head
- Positive aim swivel
- CSA certified to C22.2 N°50.



Single,
regular head



Single,
metal head



Typical Specification

Base and remote head are injection-molded thermoplastic, shockproof and flame retardant. Shall be supplied factory white or black. The setting point shall provide visual indication of the light distribution.

The fixture shall be supplied with a canopy to be installed on any standard octagonal box. The housing

shall be designed to allow lamp replacement when required.

The remote unit shall be the Lumacell model:
RS _____ .

Project / Location		Date
Contractor	Prepared by	
LUMACELL Model		



Wire Guards

460.0035-L	Wall Mount (RS10)
460.0082-L	Wall Mount (RS20)
460.0078-L	Wall Mount (RS30T)

RS10 / RS20 / RS30T

Dimensions

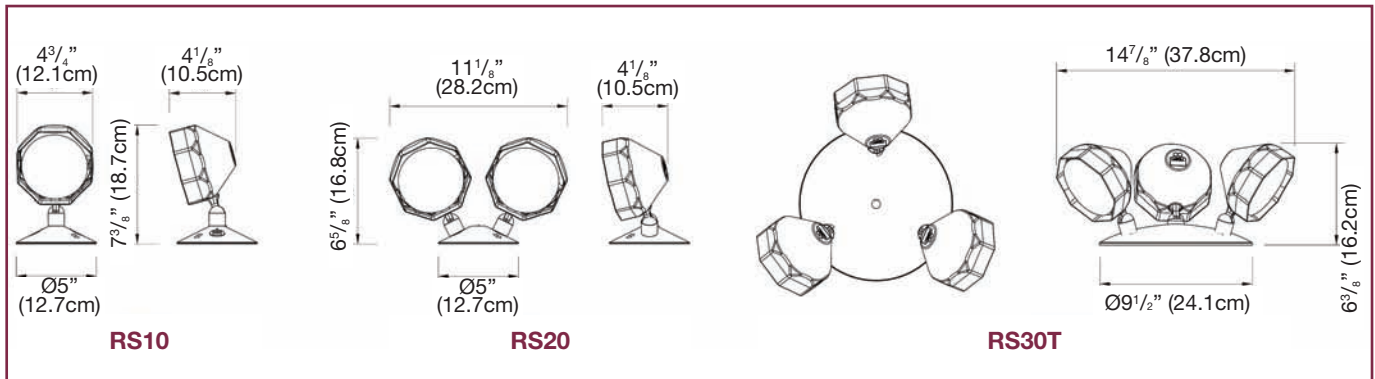

Replacement Lamps

Model	Lamp Type	Voltage-Wattage
570.0016-L	Mini tungsten, wedge base	6V-9W
570.0025-L	Mini tungsten, wedge base	12V-9W
580.0023-L	Mini Halogen (quartz), bi-pin	24V-20W

See the complete list p. 196 to 199.

Ordering Information

Series	# of Heads	Voltage/Wattage/Lamp Type	Colour	Options	
RS= PAR36	10= single head	6V9W = 6V-9W, tungsten, wedge base	Blank = factory white	Blank = no options	
	20= doublehead	6V __ W = 6V-18 or 25W, tungsten, DCB	BK = black	TC = teflon coated lens	
	30T= triple head	12V __ W = 12V-9 or 18W, tungsten, wedge base			M = metal head
		12V25W = 12V-25W, tungsten, DCB			
		24V __ W = 24V-9 or 18W, tungsten, wedge base			
		24V25W = 24V-25W, tungsten, DCB			
		Q6V __ W = 6V-8, 12 or 20W, halogen quartz bi-pin			
		Q12V __ W = 12V-8, 12, 20 or 55W, halogen quartz bi-pin*			
		Q24V __ W = 24V-20 or 70W,** halogen quartz bi-pin			
		SB6V __ W = 6V-12, 18 or 25W, tungsten, sealed beam			
		SB12V __ W = 12V-12, 18 or 25W, tungsten, sealed beam			
		QSB6V __ W = 6V-8, 12 or 20W, halogen quartz sealed beam			
		QSB12V __ W = 12V-8, 12 or 37W, halogen quartz sealed beam			
		32V __ W = 32V-18 or 25W, tungsten, DCB			
		120V __ W = 120V-10 or 15W, tungsten, DCB			
		Q120V35W = 120V-35W, halogen, DCB			
Q120V50W = 120V-50W, halogen, DCB**					
		* Only available in high temp heads, grey only			
		**Only available in metal heads			

EXAMPLE: RS106V9W

Q-BIC Remote Fixtures

Surface Mounted Series



Features

- Cubic, vandal-resistant surface-mounted fixture
- Single, double or twin cube with center body
- CSA certified to C22.2 N°50.



Typical Specification

Remote heads Series Q-BIC shall be comprised of one (single) or two (double or twin) 12-Watt adjustable halogen lamps. Each lamp shall be housed in an impact-resistant polycarbonate cube. The cube lens shall be frosted to diffuse the light.

Heads shall provide mounting holes for installation to a standard octagonal box.

The remote unit shall be the Lumacell model:
RSQ_X _____ .

In the same family...



Q-BIC

Battery Units **p. 136 - 137**

Project / Location		Date
Contractor		Prepared by
LUMACELL Model		



RSQB / RSQBD / RSQB2

Dimensions

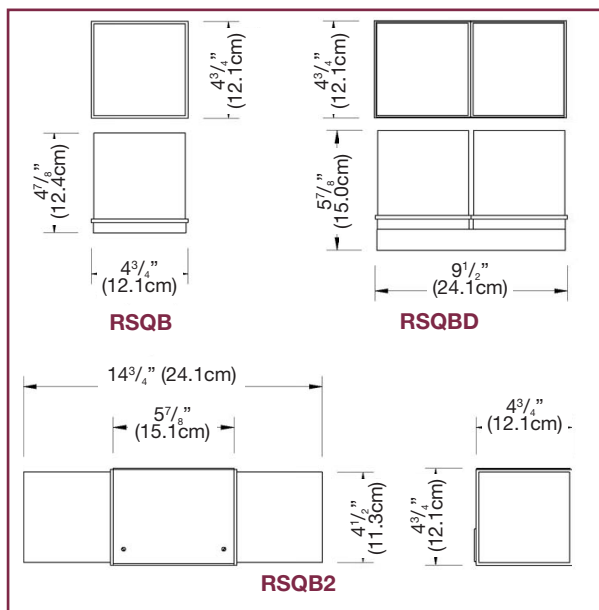

Wire Guards

460.0035-L	Wall Mount (RSQB)
460.0100-L	Wall Mount (RSQBD)
460.0032-L	Wall Mount (RSQB2)

Replacement Lamps

Model	Lamp Type	Voltage-Wattage
570.0016-L	Mini tungsten, wedge base	6V-9W
580.0011-L	Mini Halogen (quartz), bi-pin	6V-12W
580.0079-L	MR16, flood	6V-10W

See the complete list p. 196 to 199.

Ordering Information

Series	Voltage/Wattage/Lamp Type	Colour	Options
RSQB = single cube	T6V9W = 6V-9W, tungsten, wedge base	Blank = factory white	Blank = no options
RSQBD = double cube	T12V9W = 12V-9W, tungsten, wedge base	BK = black	TP = tamper proof screws
RSQB2 = twin cube	T12V18W = 12V-18W, tungsten, wedge base		*690.0454-L = tamper proof bit
	T24V9W = 24V-9W, tungsten, wedge base		
	T24V18W = 24V-18W, tungsten, wedge base		
	T32V15W = 32V-15W, tungsten, wedge base		
	6V8W = 6V-8W, quartz bi-pin		
	6V12W = 6V-12W, quartz bi-pin		
	12V8W = 12V-8W, quartz bi-pin		
	12V12W = 12V-12W, quartz bi-pins		
	24V20W = 24V-20W, quartz bi-pin		
	120V20W = 120V-20W, GU10		
	120V35W = 120V-35W, GU10		
	M6V6W = 6V-6W, MR16		
	M6V10W = 6V-10W, MR16		
	M12V12W = 12V-12W, MR16		
	M12V20W = 12V-20W, MR16		
	M12V35W = 12V-35W, MR16		
	M12V50W = 12V-50W, MR16		
	M24V20W = 24V-20W, MR16		
	M24V35W = 24V-35W, MR16		
	M24V50W = 24V-50W, MR16		

*One bit needed per order.

EXAMPLE: RSQBT6V9W

SIGNATURE Collection Remote Fixture

Surface designer Series

WP series

Weatherproof MR16 powder coated cast aluminum light head



RS*WP



Dimensions

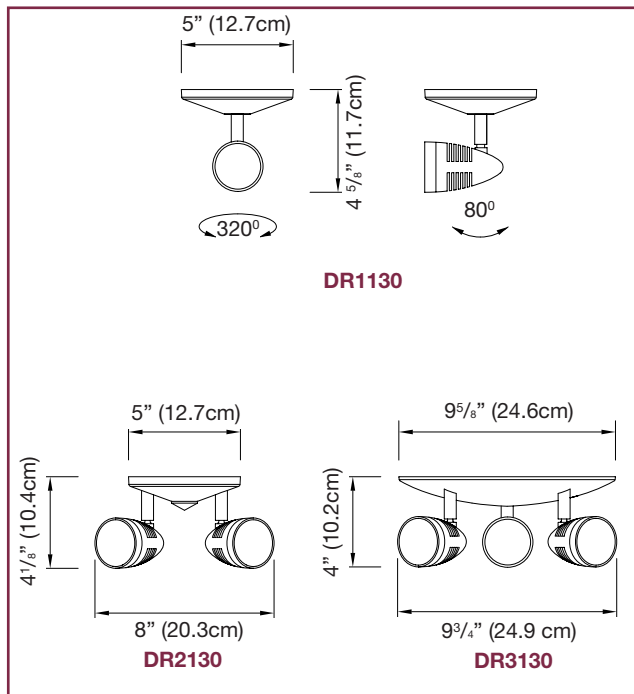

Features

- Remote head: 1, 2 or 3 head configurations
- A selection of styles and shades
- Highly resistant powder-coated, die cast aluminum construction
- 6W, 10W, 12W, 20W, 35W, and 50W availability
- Narrow beam light source
- CSA certified to C22.2 N°50.

Wire Guards

460.0029-L	Wall Mount (DR1130 / DR1160 / DR1161)
460.0032-L	Wall Mount (DR2130 / DR2160 / DR2161)
460.0078-L	Wall Mount (DR3130 / DR3160 / DR3161)

Replacement Lamps

Model	Lamp Type	Voltage-Wattage
570.0074-L	MR16 flood	6V-6W
580.0080-L	MR16 flood	12V-12W
580.0077-L	MR16 flood	24V-20W

See the complete list p. 196 to 199.

Ordering Information

Series	# of Heads	Head Style	Colour	Lamp Style	Voltage / Wattage
DR= decorative remote	1= single head	130= closed	WH= white BK= black	-MR16= MR16 lamp	6V6W= 6V-6W
	2= double head				6V10W= 6V-10W
	3= triple head				12V12W= 12V-12W
					12V20W= 12V-20W
					12V35W= 12V-35W
					12V50W= 12V-50W
					24V20W= 24V-20W
					24V35W= 24V-35W
					24V50W= 24V-50W

EXAMPLE: DR1130WH-MR166V6W

Project / Location		Date
Contractor		Prepared by
LUMACELL Model		



SIGNATURE / WP

WP

Dimensions

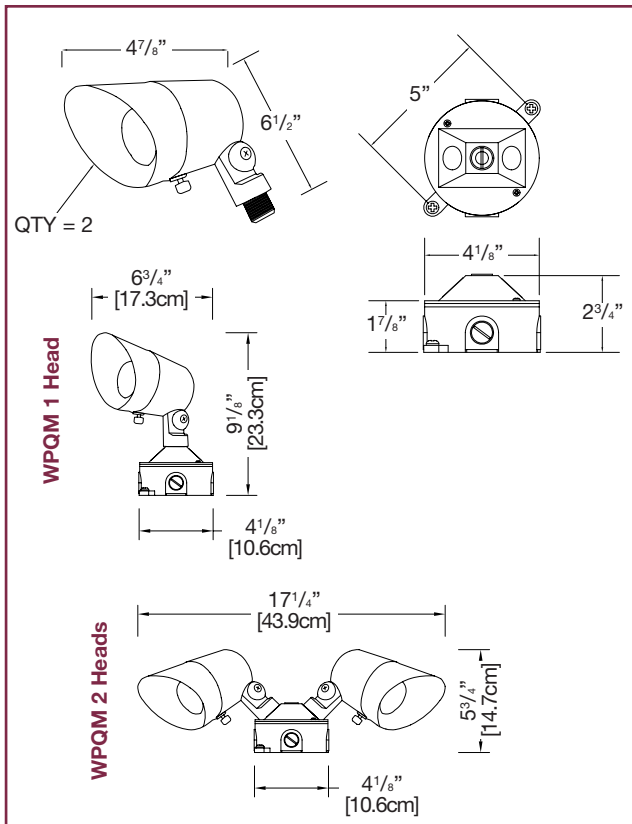

Features

- Weatherproof MR16 powder coated cast aluminum light head
- Up to 24Volts 50Watts
- Available single or double head
- Preinstalled on a Red Dot® weather proof junction box:
 - Five Outlets, 4 1/8" Diameter
 - Copper-free* aluminum provides increased corrosion resistance.
 - Precision cast and machined surfaces permit safer wire pulling.
 - Clean cover edges provide good gasket sealing.
 - Precision NPT threads allow trouble-free field installation for rigid, IMC or EMT conduit.
 - Deep slotted stainless steel cover screws for faster installation.
- For use with 6V, 12V or 24V DC MR16 lamps

Replacement Lamps

Model	Lamp Type	Voltage-Wattage
580.0079-L	MR16 flood	6V-10W
580.0080-L	MR16 flood	12V-12W
580.0070-L	MR16 flood	24V-12W

See the complete list p. 196 to 199.

Ordering Information

Series	# of Heads	Voltage	Wattage	Colour
WP = weather proof remotes, complete with Red Dot junction box	Blank = single head	-6V = 6 Vdc	10W = 10 watts, MR16 (6V only)	Blank = black head/grey junction box
	D = double head	-12V = 12Vdc	12W = 12 watts, MR16 (12&24V)	
		-24V = 24Vdc	20W = 20 watts, MR16 (12&24V)	
			30W = 35 watts, MR16 (12&24V)	
			50W = 50 watts, MR16 (12&24V)	
			20WH = 20 watts, MR16, IR* (12V only)	
			35WH = 35 watts, MR16, IR* (12V only)	
			50WH = 50 watts, MR16, IR* (12V only)	
*IR= high output lamp				

EXAMPLE: WP6V10W

RSTH SIGNATURE Remote Collection

Recessed designer series



Features

- Contemporary, enduring designs
- 6W, 10W, 12W, 20W, 35W, and 50W lamps
- Wide beam MR16 (flood) light source
- EFR8NB and EFR8R are made of power coated or electro-plate steel
- EF9 and EFR2 are made of die-cast
- Will blend in with regular decorative recessed fixtures
- Choice of housing for new construction or insulated ceiling
- Certified CSA C22.2 №250



RSTH18NB



RSTH19



RSTH18R



RSTH24

Typical Specification

The contractor will supply and install Lumacell Signature Collection recessed heads and housing. Recessed heads will be constructed of durable powder coated, metal and use MR16 halogen lamps. The RSTH18 series shall be made of steel. The RSTH 19 and RSTH24 series shall be made of die-cast aluminum.

The light source will be _____ volts, _____ watts MR16 halogen wide beam (flood) or otherwise specified.

The recessed heads RSTH series shall be installed only with the LU-GRHR series of recessed cabinets (to order separately).

The remote unit shall be the Lumacell model:
RSTH _____ ,

and the housing shall be the Lumacell model:
LU-GRHRO _____.

Project / Location		Date
Contractor		Prepared by
LUMACELL Model		



SIGNATURE RSTH

Dimensions

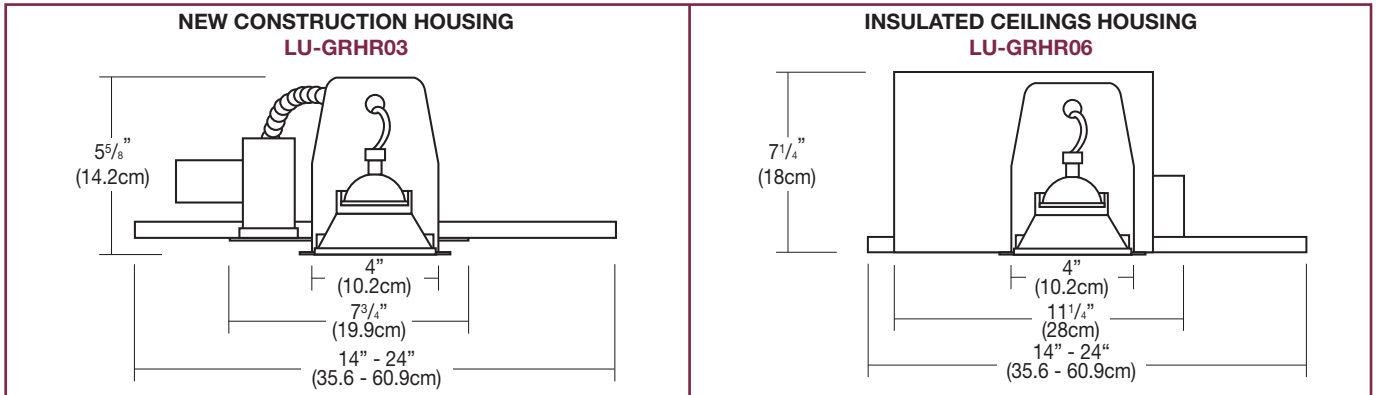

Cabinet

LU-GRHR03	Uninsulated ceiling 6-24V	New construction
LU-GRHR04	Uninsulated ceiling 6-24V	Old construction
LU-GRHR05	Uninsulated ceiling 6-24V	New construction
LU-GRHR06	Insulated ceiling 120V GU10	New construction

Replacement Lamps

Model	Lamp Type	Voltage-Wattage
580.0079-L	MR16 flood	6V-10W
580.0080-L	MR16 flood	12V-12W
580.0077-L	MR16 flood	24V-20W

See the complete list p. 196 to 199.

Ordering Information

Series	Head Style	Colour	Lamp Type	Voltage / Wattage
RSTH= decorative recessed remote	18NB= flat	WH= white	-MR16= MR16 lamp	6V6W= 6V-6W
	18R= concave	BK= black (18R, 19 & 24 series only)		6V10W= 6V-10W
	19= concave	BN= brushed nickel (18R, 18NB & 24 series only)		12V12W= 12V-12W
	24= pop-out	CH= chrome (24 series only)		12V20W= 12V-20W
		PB= polished brass (24series only)		12V35W= 12V-35W
				12V50W= 12V-50W
				24V20W= 24V-20W
				24V35W= 24V-35W
				24V50W= 24V-50W
				120V20W= 120V-20W, GU10*
				120V35W= 120V-35W, GU10*
				120V50W= 120V-50W, GU10*
				* Available only with 18R and 19 series and with LU-GRHR05 cabinet

EXAMPLE: RSTH18NBWH-MR166V6W

RS*WP / RS*WPRB/ RS*QWPBH

Weatherproof Remote Fixture Series



RS*WP

Dimensions

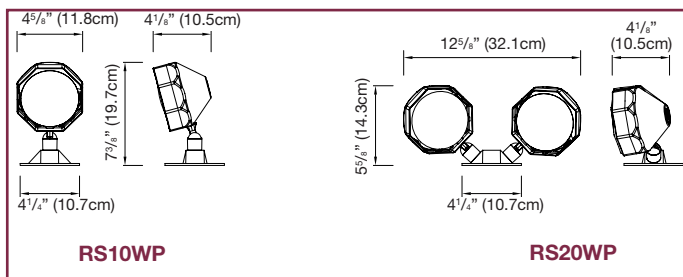

Features

- PAR 36, surface-mounted industrial remote fixtures
- Available in single, double or triple head fixtures
- Durable thermoplastic construction suitable for industrial or high abuse areas
- CSA certified to C22.2 N°50.

Replacement Lamps

Model	Lamp Type	Voltage-Wattage
570.0016-L	Tungsten	6V-9W
570.0025-L	Tungsten	12V-9W
570.0079-L	Tungsten	24V-9W

See the complete list p. 196 to 199.

Wire Guards

460.0035-L	Wall Mount (RS10WP)
460.0082-L	Wall Mount (RS20WP)

Ordering Information

Series	# of Heads	Voltage/Wattage/Lamp Type	Colour	Options
RS= PAR 36	10= single head	WP6V9W = 6V-9W, tungsten, wedge base	Blank = black	Blank = no options
	20= double head	WP6V_W = 6V-18 or 25W, tungsten, D.C.B.	WH = factory white	TC = teflon coated lens
		WP12V_W = 12V-9 or 18W, tungsten, wedge base		
		WP12V25W = 12V-25W, tungsten, D.C.B.		
		WP24V_W = 24V-9 or 18W, tungsten, wedge base		
		WP24V25W = 24V-25W, tungsten, D.C.B.		
		QWP6V_W = 6 V-8, 12 or 20W, halogen, quartz bi-pin		
		QWP12V_W = 12V-8, 12, 20 or *55W, halogen, quartz bi-pin		
		QWP24V_W = 24V-20 or *70W, halogen, quartz bi-pin		
		SBWP6V_W = 6V-9, 12, 18 or 25W, tungsten, sealed beam		
		SBWP12V_W = 12V-12, 18 or 25W, tungsten, sealed beam		
		QSBWP6V_W = 6V-8, 12 or 20W, halogen, quartz, sealed beam		
		QSBWP12V_W = 12V-8, 12 or 37W, halogen, quartz, sealed beam		
		WP32V_W = 32V-18 or 25W, tungsten, D.C.B.		
		WP120V_W = 120V-10 or 15W, tungsten, D.C.B.		
		Q120V35W = 120V-35W, halogen, DCB		
Q120V50W = 120V-50W, halogen, DCB**				
		*Only available in high temp heads		
		**Only available in metal heads		

EXAMPLE: RS10WP6V9W

Project / Location		Date
Contractor		Prepared by
LUMACELL Model		



RS*WP / RS*WPRB / RS*QWPBH

RS*WPRB



Dimensions

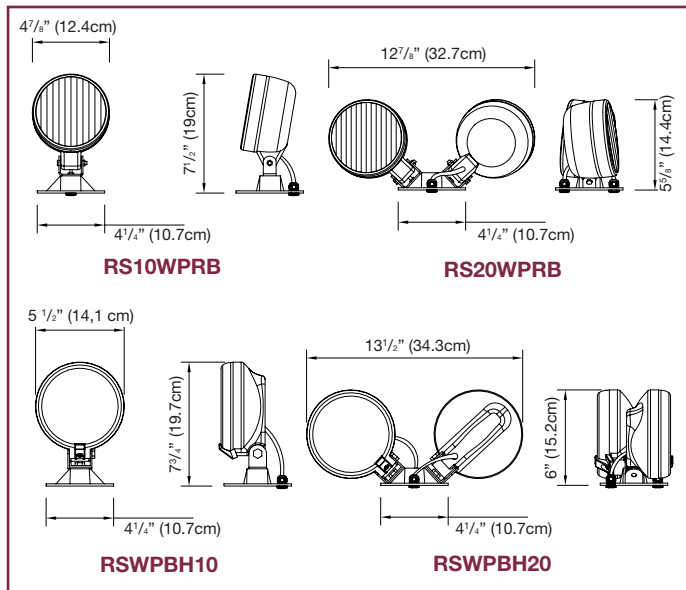

Features

- Sealed beam, PAR 36, surface-mounted, rubber coated industrial remote fixture
- For use in high pressure hose down areas
- Available only in black
- CSA certified to C22.2 N°50.

Replacement Lamps

Model	Lamp Type	Voltage-Wattage
550.0026-L	Tungsten	12V-12W
550.0027-L	Tungsten	12V-18W
550.0023-L	Tungsten	12V-25W
*580.0030-L	Halogen	12V-55W
*580.0031-L	Halogen	24V-70W

* Lamps for RS10QWPBH

See the complete list p. 196 to 199.

Ordering Information

Series	# of Heads	Voltage/Wattage/Lamp Type	Options
RS= PAR 36	10= single head	SBWPRB6V_W = 6V-9, 12, 18 or 25W, tungsten, sealed beam	Blank= no options
	20= double head	SBWPRB12V_W = 12V-12, 18 or 25W, tungsten, sealed beam	TC= teflon coated lens (RB only)
		QSBWPRB6V_W = 6V-8, 12 or 20W, halogen, quartz, sealed beam	
		QSBWPRB12V_W = 12V-8, 12 or 37W, halogen, quartz, sealed beam	
RS	10= single head	QWPBH24V70W = 24V-70W, halogen, quartz, H3	Blank= no options
	20= double head	QWPBH12V55W = 12V-55W, halogen, quartz, H3	
NOTE : " " insert wattage required			

EXAMPLE: RS10SBWPRB6V9W

MQM*NX Series Remote Fixture

NEMA-4X certified



Features

- Delivers unsurpassed pathway illumination up to 70 feet, center-to-center (with 12V-20W high-output lamp)
- Fully gasketed cast aluminum back plate with clear polycarbonate cover
- UV and impact resistant cover
- Choice of single or double lamp models
- Available in 6, 12 and 24 Volt models with various wattages
- High efficiency MR16 lamps up to 20W
- Easy lamp replacement
- Comes standard with tamper-proof screws and bit
- NSF Certified for food processing plants
- NEMA-4X Certified
- CSA Certified to C22.2 N^o. 50



Made in Canada



NEMA-4X

Typical Specification

Supply and install Lumacell MQM-NX Series remote emergency lighting fixtures. These remote fixtures will consist of either single or double lamp configurations according to the design. These fixtures shall be fully gasketed with a die cast aluminum back plate and a clear heavy-duty UV resistant polycarbonate light cover. Units shall be NEMA-4X and NSF certified and specifically designed for high abuse areas, wet and cold weather locations as well as for use in food processing plants. The standard unit will come with stainless steel tamper-proof screws and bit.

The remote fixture shall be certified to CSA C22.2 N^o.50. The head(s) shall be fully adjustable without tools and should be equipped with MR16 halogen lamp(s) of _____ volts _____ watts.

The remote unit shall be the Lumacell model:
MQM__NX _____ .

In the same family...



RG-NX

Battery Units p. 112 - 113



MQM-NC

Remote Fixtures p. 168- 169



MQM-HZ Class I, Div. 2

Remote Fixtures p. 194 - 195

Project / Location		Date
Contractor		Prepared by
LUMACELL Model		



MQM*NX

Dimensions

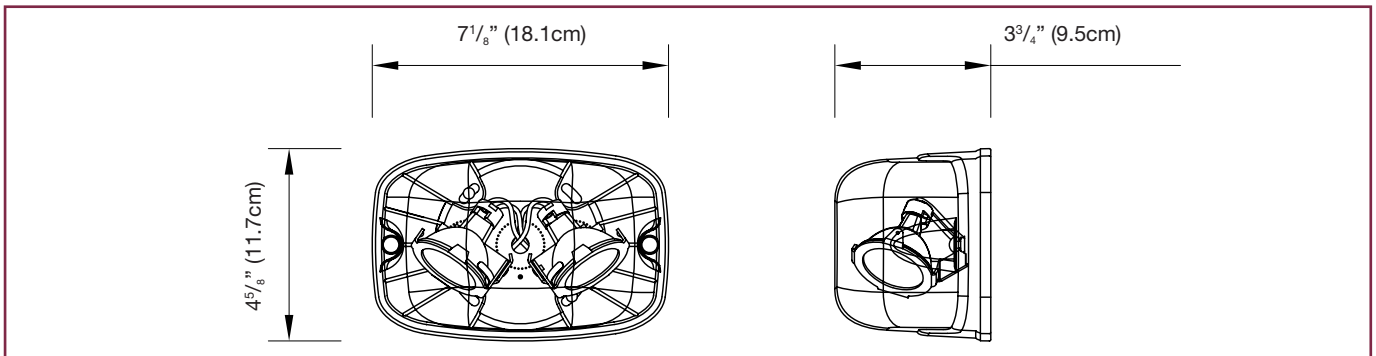

Replacement Lamps

Model	Lamp Type	Voltage-Wattage
580.0079-L	MR16 flood	6V-10W
580.0080-L	MR16 flood	12V-12W
580.0070-L	MR16 flood	24V-12W

See the complete list p. 196 to 199.

Ordering Information

Series	Lamp Type/Voltage/Wattage	Colour
MQM1NX = NEMA-4X, one lamp	6V6W = 6V-6W, MR16	Blank = factory white
MQM2NX = NEMA-4X, two lamps	6V10W = 6V-10W, MR16	BK = black
	12V12W = 12V-12W, MR16	SG = grey
	12V20WH = 12V-20W, MR16 high output	
	24V12W = 24V-12W, MR16	
	24V20W = 24V-20W, MR16	
	120V20W = 120V-20W, GU10	
	L = 12V-5W, LED	
		*Other colours available on demand. Consult your sales representative.

EXAMPLE: MQM1NX6V6W

RS10XP Series Remote Fixture

Hazardous Location



Features

- CSA Certified for use in hazardous locations:
 - Class I, Divisions 1 and 2, Groups A, B, C, D
 - Class II, Divisions 1 and 2, Groups E, F, G
 - Class III, Divisions 1 and 2
- Die-cast aluminum body with gray epoxy powder coat finish
- Clear, impact and heat resistant prismatic glass globe
- Available in 6, 12 and 24V
- Available with single-lamp or twin-lamp combination
- New, easy-to-build catalogue number based on the Lumacell Severity Codes



Typical Specification

Supply and install the Lumacell RS10XP Series of hazardous location remote heads. The head housing will be die cast aluminum with gray epoxy powder coat finish. The lens shall be a clear, impact and heat resistant prismatic glass globe. The head shall be factory sealed. External seals shall not be required.

The remote shall come complete with a _____ mounting connection and include _____ lamp(s) rated _____ volts _____ watts.

The remote head shall be suitable for Class _____, Division _____, Group _____.

The remote unit shall be the Lumacell model:
RS _____.

Replacement Lamps

Model	Lamp Type	Voltage-Wattage
580.0011-L	Halogen	6V-12W
580.0015-L	Halogen	12V-12W
580.0027-L	Halogen	12V-20W
580.0023-L	Halogen	24V-20W

See the complete list p. 196 to 199.

In the same family...



RG-X

Exit Signs p. 82 -89

Project / Location		Date
Contractor		Prepared by
LUMACELL Model		



RS10XP

Dimensions

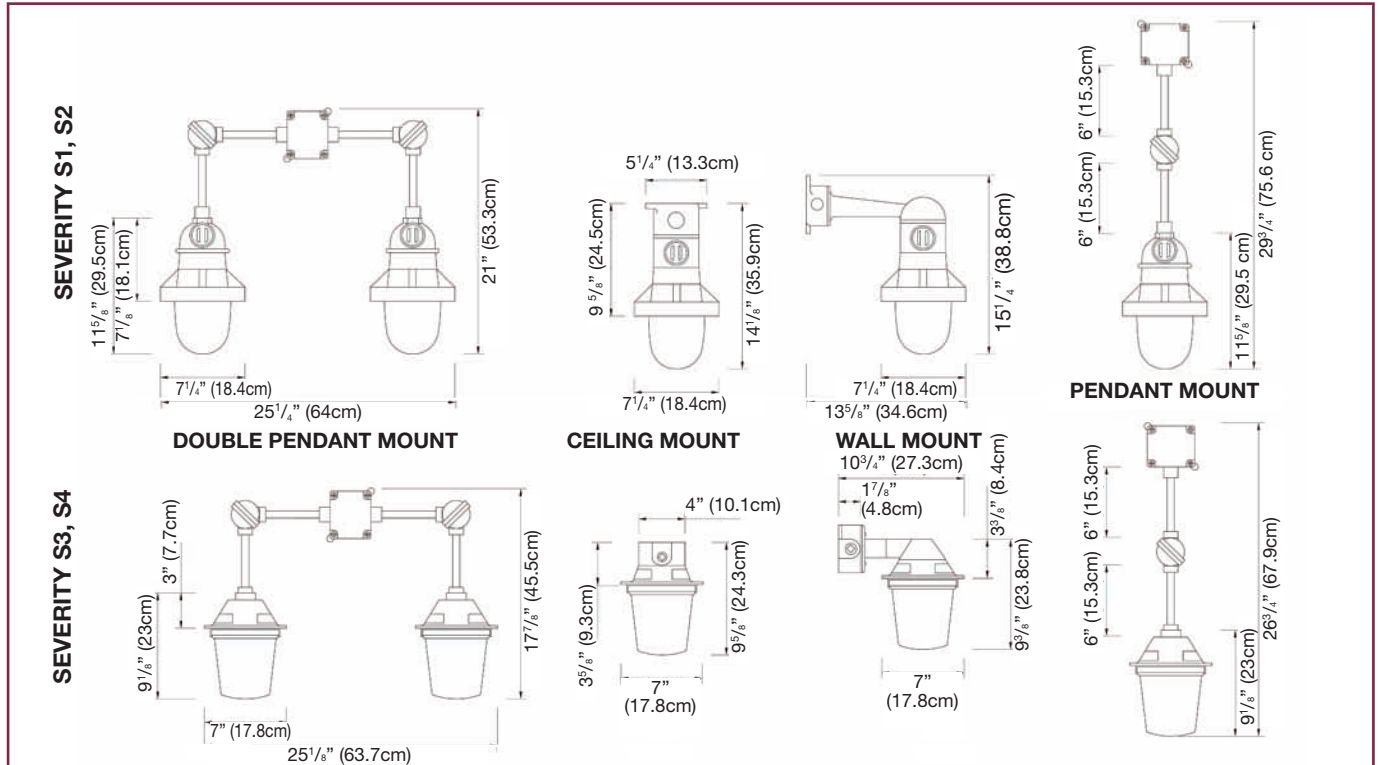

Ordering Information

Before ordering, identify the environment of your application: Class ____, Division ____, Group ____.
Refer to the following chart for the Severity Code (1) to use in your catalogue number:

1.	Environment	Severity Code
	Cl. I, Div. 1, Gr. A, B	S1
	Cl. I, Div. 1, Gr. C, D	S2
	Cl. I, Div. 2, Gr. A, B, C, D	S3
	Cl. II, Div. 1 & 2, Gr. E, F, G	S4
	Cl. III, Div. 1 & 2	

For additional information, please look at the table below(2):

2.	Certification Guide for Remote Lighting Fixtures (40°C ambient)			
Severity Code	S1	S2	S3	S4
Temperature Code	T4A	T6	T1	T3C (E.G.F.)
CSA/UL rating	Max. 120°C	Max. 85°C	Max. 450°C	Max. 165°C

3. RS10-XP

Series	Voltage	Lamp Type/ Wattage/Type	Severity Code	Mounting
RS10XP = single remote 1 lamp	6V = 6 volts	12W = halogen, 6V-12W, quartz bi-pin	S1 = see chart	C = ceiling mount
RS20XP = single remote 2 lamps	12V = 12 volts	20W = halogen, 12, 24V-20W, quartz bi-pin	S2 = see chart	P = pendant mount
*RS20FXP = double remote 1 lamp	24V = 24 volts		S3 = see chart	W = wall mount
*Pendant mount only.			S4 = see chart	

EXAMPLE: RS10XP6V12WS1C

MQM*HZ Series Remote Fixture

Hazardous Location



Features

- Certified Class I Division 2, Groups A, B, C and D as per CSA C22.2 N°. 50 and N°.137-M1981, Class I, Zone 2, Groups IIC, IIB and IIA
- Temperature Codes: T3B (10W and 12W MR16 lamps) and T2C (20W MR16 lamps), as per Canadian Electrical Code, Part I and CSA C22.2 N°.137-M1981)
- Extreme operational temperature range: -40°C to +40°C.
- Choice of single- or double-lamp models.
- High-efficacy MR16 halogen lamps of 10W, 12W and 20W (see specification table)
- Input voltage: 6V, 12V, 24V or 120V
- Fully gasketed die-cast aluminum back plate
- Clear polycarbonate cover, UV and impact resistant
- Easy installation on a 4-inch octagonal box (included)
- Comes standard with tamper-proof screws and bit



Made in Canada



Typical Specification

Supply and install Lumacell MQM-HZ Series remote emergency lighting fixture. The fixture shall have a single- or double-lamp configuration (as specified) and shall include a fully gasketed die-cast aluminum back plate and a clear heavy-duty UV resistant polycarbonate cover. The fixture shall come standard with a 4-inch octagonal box, stainless steel tamper-proof screws and dedicated screwdriver bit.

The fixture shall be certified for use in hazardous locations Class I, Division 2, Groups A, B, C and D

and shall be listed to CSA C22.2 N°. 50 and CSA C22.2 N°.137-M1981. The fixture shall be rated with a temperature code for the selected lamps as in the table below.

Each lamp in the fixture shall be able to be oriented without tools and should be equipped with MR16 halogen lamp(s) of ____Volts ____ Watts.

The remote unit shall be the Lumacell model:
MQM __ HZ _____.

In the same family...



RGA

Battery Units p. 120 - 121



MQM-NC

Remote Fixtures p. 168 - 169



MQM-NX NEMA-4X

Remote Fixtures p. 190 - 191

Project / Location		Date
Contractor	Prepared by	
LUMACELL Model		



MQM*HZ

Dimensions

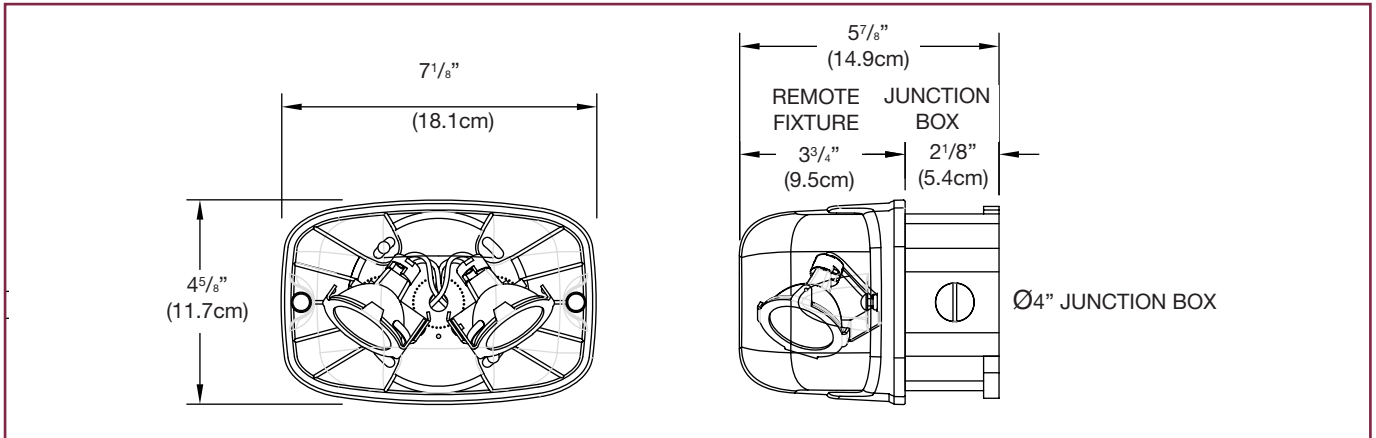

Replacement Lamps

Model	Lamp Type	Voltage-Wattage
580.0079-L	MR16 flood	6V-10W
580.0068-L	MR16-IR flood (High output)	12V-20W
580.0070-L	MR16 flood	24V-20W

See the complete list p. 196 to 199.











Ordering Information

Series	Voltage/Wattage/Lamp Type	Colour
MQM1HZ = single lamp	6V10W = 6V-10W, MR16	SG = grey
MQM2HZ = double lamp	12V12W = 12V-12W, MR16	
	12V20W = 12V-20W, MR16	
	12V20WH = 12V-20W, MR16 high output	
	24V12W = 24V-12W, MR16	
	24V20W = 24V-20W, MR16	
	120V20W = 120V-20W, MR16	

EXAMPLE: MQM1HZ6V10W SG

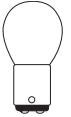

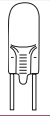







Lamp Chart



	LAMP TYPE	CODE	VOLTAGE	 CAMRAY	 MQM*NC	 SAF-T-RAY	 PHANTOM	 DIVIDER®	 MT / MQ MQM
HIGH INTENSITY TUNGSTEN LAMPS DOUBLE CONTACT BAYONET BASE	 S-8	570.0040	24V - 18W						
		570.0037	6V - 18W						
		570.0031	12V - 25W						
		570.0061	24V - 25W						
	 RP-11	570.0120	120V - 15W						
		570.0010	6V - 9W						
		570.0015	32V - 15W						
		570.0025	32V - 25W						
		570.0020	6V - 13W						
		570.0011	12V - 9W						
		570.0038	6V - 25W						
		570.0022	12V - 13W						
		570.0030	12V - 18W						
		570.0058	24V - 9W						
BI-PIN HALOGEN LAMPS	 T-2 3/4	580.0012	6V - 6W						
		580.0017	6V - 10W						
		580.0013	6V - 8W						X
		580.0011	6V - 12W						X
		580.0022	6V - 20W						
		580.0014	12V - 8W						X
		580.0015	12V - 12W						X
	 T-2 1/4	580.0023	24V - 20W						
		580.0016	12V - 14W						
		580.0027	12V - 20W						
		580.0030	12V - 50W						
	 H3	580.0031	24V - 20W						
		580.0030	12V - 55W						
INCANDESCENT LAMPS WEDGE BASE	 T-5	580.0031	24V - 70W						
		570.0026	6V - 7.2W						
		570.0016	6V - 9W					X	X
		570.0025	12V - 9W					X	X
		570.0028	12V - 8W						
		570.0029	12V - 18W						X
		570.0045	24V - 9W					X	X
		570.0046	24V - 18W						X
570.0012	6V - 5.4W					X			

Lamp Chart



	LAMP TYPE	CODE	VOLTAGE	 CAMRAY	 MQM*NC	 SAF-T-RAY	 PHANTOM	 DIVIDER®	 MT / MQ MQM
MR16 HALOGEN LAMPS	 MR16	580.0074	6V - 6W		X				X
		580.0079	6V - 10W (flood)		X	X			X
		580.0080	12V - 12W (flood)		X	X	X		X
		580.0075	12V - 20W *						X
		580.0064	12V - 20W (flood)			X	X		
		580.0068	12V - 20WH (flood)		X	X	X		
		580.0090	12V - 35WH (flood)				X		
		580.0089	12V - 50WH (flood)				X		
		580.0083	12V - 35W (flood)				X		
		580.0076	12V - 50W (flood)				X		
		580.0077	24V - 20W (flood)		X	X	X		
		580.0070	24V - 12W (flood)		X	X	X		X
		580.0084	24V - 35W (flood)				X		
		580.0078	24V - 50W (flood)				X		
		580.0065	120V - 20W (flood)		X	X			
		580.0066	120V - 35W (flood)						
580.0067	120V - 50W (flood)								
LED LAMPS	 MR16 Shape	580.0093	12V - 5W		X				X
SEALED BEAM HALOGEN LAMPS	 PAR36	550.0036	6V - 8W						
		550.0037	6V - 10W						
		550.0021	6V - 20W						
		550.0024	12V - 8W						
		550.0025	12V - 12W						
SEALED BEAM INCANDESCENT LAMPS	 PAR36	550.0018	6V - 8W						
		550.0016	6V - 18W						
		550.0017	6V - 25W						
		550.0026	12V - 12W						
		550.0027	12V - 18W						
XENON LAMPS	 T-3 1/4	570.0213	6V - 6W	X					
		570.0214	6V - 10W	X					
		570.0215	12V - 6W	X					
		570.0216	12V - 10W	X					

Glossary

A	ammeter	Used to measure the current being supplied to the battery while in charge mode.
AT	Auto-Test	Automatically tests and continuously monitors your emergency lighting unit. If a problem occurs, the unit will send a visual (flashing or blinking LED indicator) and audible warning. Complies with Fire Code requirements.
ATN	Auto-Test, non-audible	Automatically tests and continuously monitors your emergency lighting unit. If a problem occurs, the unit will send a visual (flashing or blinking LED indicator) warning. Complies with Fire Code requirements.
CT	Cab-tire	Unit supplied with a cab-tire cable used for special hardwire applications.
CW1	cold weather, 120Vac	120Vac input cold weather protection feature for applications where temperatures can reach -40° C
CW3	cold weather, 347Vac	347Vac input cold weather protection feature for applications where temperatures can reach -40° C
DPF6	6cct. Fuse panel	Used to facilitate the connection of multiple input load circuits in high power battery units.
HHC	remote test transmitter	Used to perform maintenance tests by means of radio transmitter along with a radio receiver (RRT option) on battery units that are out of reach.
HTR	heather & thermostat	Like a heatblanket, used to keep internal temperature optimal for battery units that are installed in cold environments.
LC	line cord (120V)	When ordering a battery unit with the LC option, we supply and pre-install a line cord with a standard 3 prong 120V plug. Just hang the fixture and plug it in to a standard receptacle! Only available on 120V units.
LD	lamp disconnect	To disconnect the emergency lighting load in an area that is not in use during a prolonged power failure or while area is no longer being occupied.
LS	Laser	Used to remotely test battery units by means of pointing a laser at the battery unit.
LTS	light activated test switch	Used to remotely test battery units by pointing a flashlight at a photocell mounted on the bottom of a battery unit.
TC	teflon coated lens	A protective teflon coating that is applied to the glass lens of a lighting fixture to prevent broken shards from falling in the event the glass is accidentally broken or vandalised.
RRT	remote test receiver	Used to perform maintenance tests by means of radio receiver in conjunction with a transmitter(HHC option) on battery units that are out of reach. Simply point the receiver at the unit.
NEX	Nexus system interface	The NEXUS system interface is a computerized maintenance system for emergency lighting that, once programmed, will perform the tests, keep written records and send notification if anything needs to be fixed. One full system can address hundreds of units in as many buildings as you need from a single location.
T3	15 minutes time delay	Normally, when the a.c. is restored, all emergency lighting lamps are turned off. However, in some cases such as when metal halide lamps are used, it is possible that the general lighting will not be available for several minutes after the blackout (or brownout) period. Battery units with the T3 option will keep some energy in store to ensure that the emergency lighting stays on or comes back on for at least 15 minutes once the regular a.c. power has been restored.
TD	time delay (programmable)	Same as the T3 option but can be programmed for 5, 10, 15 or 20 minutes delay.
TP	tamper proof screws	Screws that require a special bit. Can be used on certain units to deny access to unauthorized personnel.
TL	twistlock plug	Used to facilitate the connection and removal of battery units for maintenance purposes.
TMBB	a.c./d.c. terminal block	Used to facilitate the connection of large gauge input cables.
TMBD	d.c. terminal block	Used to facilitate the connection of large gauge d.c. input cables.
TMBK	a.c. terminal block	Used to facilitate the connection of large gauge a.c. input cables.
V	voltmeter	Indicates voltage being supplied to the battery when in charge mode.