



RGS*NX Battery Units

6, 12 and 24 volts,
NEMA-4X Rated

PROJECT _____
 LOCATION _____
 DATE _____
 CONTRACTOR _____
 PREPARED BY _____
LUMACELL
 MODEL _____

RGS*NX SERIES

Harsh environment emergency lighting units

The RGS*NX Series battery units are specifically designed for use in industrial facilities where equipment is exposed to dust, water, oil or corrosive substances. NEMA-4X standard to protect circuitry from harmful dust or liquid sprays, sealed and gasketed unit made of fiberglass reinforced polyester.

FEATURES

- Delivers great pathway illumination up to 70 feet, center to center (with M20WH lamp)
- Fully gasketed fiberglass reinforced polyester housing - NEMA 4X
- Solid-state pulse-type charger – current-limited, temperature-compensated, short-circuit proof and reverse-polarity protected
- Unit comes standard with electronic lockout and brownout circuits
- Sealed dust-proof transfer relay, test switch and LED indicator lights
- Long-life, maintenance-free sealed lead acid battery
- Standard 120/347Vac input voltage with line cord kit
- Auto-test and diagnostic (optional)
- NEXUS® compatible (for more information on NEXUS®, please consult your sales representative)

TYPICAL SPECIFICATIONS

Supply and install the Lumacell **NEMA-4X Rated RGS*NX** Series battery unit. Specifically designed for high abuse areas and wet locations, the fiberglass reinforced polyester housing shall be fully gasketed as well as the clear heavy-duty UV resistant polycarbonate lamp enclosure. The lamps shall be fully adjustable without tools and shall be high efficiency halogen or LED MR16. The Lumacell Smart Diagnostic Micro controller board shall supply the rated load for a minimum of a 1/2 hour to 87.5% of the rated battery voltage. The unit shall be rated 120V or 347V, 60 Hz and shall have an output of _____ volts.

The charger shall be fully computer tested and its charge voltage factory set to ± 1% tolerance. Chargers with field-adjusted potentiometers are not acceptable. A pulse-type charger shall be employed to promote long battery life and reduce the potential for grid corrosion. The charger shall provide a continuous high charge to recharge the battery, when the battery is at full capacity, the charger will shut-off. Periodically the charger shall provide a pulse of energy to keep the battery topped off. The Pulse charge shall be current limited and precisely regulated by a micro-processing circuit, which samples the battery in relation to its temperature, state or charge and input voltage fluctuations.

The charger shall be current limited, temperature compensated, short-circuit proof and reverse polarity protected. The unit shall be furnished with an electronic lockout circuit, which will connect the battery when the AC circuit is activated, and an electronic brownout circuit, which will activate the emergency lights when utility power dips below 75% of nominal voltage. A low voltage battery protection circuit shall be provided and will disconnect the battery from the fused output circuit at the end of discharge. The unit shall self-test for 1 minute every 30 days, 10 minutes on the 6th month and 30 minutes every 12 months. The unit shall be capable of full recharge in compliance with CSA specifications. The unit shall be furnished with sealed dust tight relay, a test switch and diagnostic LED indicator lights to continuously monitor the status of the unit: Battery Failure, Battery Disconnected, Charger Failure, Lamp Failure, Service Alarm, AC "ON", Charger High Rate.

The unit shall be **Lumacell** model: _____.

DIMENSIONS

Dimensions are approximate and subject to change.

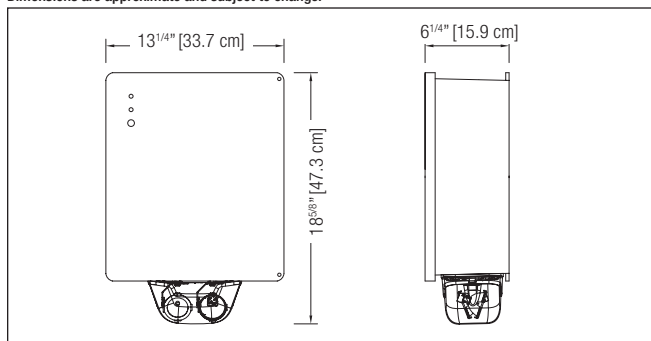

WIRE GUARDS

| | |
|------------|------------|
| 460.0034-L | Wall Mount |
|------------|------------|



RGS*NX Battery Units

6, 12 and 24 volts,
NEMA-4X Rated



RGS*NX SERIES

POWER CONSUMPTION AND UNIT RATING

| MODEL | AC SPECS | | WATTAGE CAPACITY | | | | |
|------------|------------|---------------|------------------|------|------|------|------|
| | | | 30MIN | 1H00 | 1H30 | 2H00 | 4H00 |
| RGS36NX | 120/347Vac | 0.10/0.04 Amp | 36 | 21 | 15 | 12 | 6 |
| RGS72NX | | 0.22/0.08 Amp | 72 | 42 | 30 | 24 | 12 |
| RGS108NX | | 0.22/0.08 Amp | 108 | 63 | 45 | 36 | 18 |
| RGS180NX | 120/347Vac | 0.22/0.08 Amp | 180 | 105 | 75 | 60 | 30 |
| RG12S144NX | | 0.40/0.14 Amp | 144 | 84 | 60 | 48 | 24 |
| RG12S200NX | | 0.41/0.14 Amp | 200 | 117 | 83 | 67 | 33 |
| RG12S250NX | | 0.41/0.14 Amp | 250 | 144 | 100 | 83 | 42 |
| RG24S144NX | 120/347Vac | 0.55/0.20 Amp | 144 | 84 | 60 | 48 | 24 |
| RG24S288NX | | 0.67/0.23 Amp | 288 | 168 | 120 | 96 | 48 |
| RG24S350NX | | 0.67/0.23 Amp | 350 | 200 | 144 | 108 | 60 |

ORDERING INFORMATION

| SERIES | CAPACITY | HOUSING | # OF HEADS | HEAD STYLE/LAMP WATTAGE | AC VOLTAGE | OPTIONS |
|----------------------------|--|------------------------|---|--|---|---|
| RGS = 6 volts | 72 = 72 watts 108 = 108 watts 180 = 180 watts | NX = NEMA-4X | Blank = no head 1 = one head 2 = two heads | LD1 = 6V, 4W MR16 LED LD7 = 12V, 4W MR16 LED LD13 = 24V, 4W MR16 LED M6W = 6V6W MR16 M10W = 6V10W MR16 M12W = 12V12W MR16 M20W = 12V, 24V 20W MR16 M20HW = 12V, 20W high output | Blank = 120/347 Vac input ZC = 277 Vac input | A = ammeter AT = auto-test HTR = heater & thermostat 120V HTR3 = heater & thermostat 347V LD = lamp disconnect LTS = light activated test switch RRT = remote test receiver T3 = time delay 15 Min TMBB = A.C./D.C. terminal block TMBD = D.C. terminal block TMBK = A.C. terminal block V = voltmeter |
| RG12S = 12 volts | 144 = 144 watts 200 = 200 watts 250 = 250 watts | | | | | |
| RG24S = 24 volts | 144 = 144 watts 288 = 288 watts 350 = 350 watts | | | | | |

EXAMPLE: RG24S350NX2M20W