



RGS*TB Battery Units

Decorative 6, 12 and 24 volts
T-Bar Unit

PROJECT _____
 LOCATION _____
 DATE _____
 CONTRACTOR _____
 PREPARED BY _____
LUMACELL
 MODEL _____

RGS*TB SERIES

Fully recessed units for T-Bar mounting in suspended ceilings.

The **RGS-TB Series** battery units are designed for T-bar ceiling grid installation. This slim-line, unobtrusive unit is ideally suited for any commercial location where there is limited wall space and where the greater directional flexibility of ceiling-mounted heads is needed to provide greater light distribution.

FEATURES

- Rugged steel cabinet with corrosion-resistant undercoating.
- Battery and charger are concealed above the ceiling level in the unit cabinet
- Removable panel provides easy access to battery and circuitry
- Test switch and LED indicators are mounted on the visible bottom panel
- Units mount quickly and easily in standard 2' x 2' or 2' x 4' grids without any additional hardware
- Solid-state pulse-type charger – current-limited, temperature-compensated, short-circuit proof and reverse-polarity protected
- Unit comes standard with electronic lockout and brownout circuits
- Sealed dust-proof transfer relay, test switch and LED indicator lights
- Long-life, maintenance-free lead acid battery
- Emergency lighting heads requiring no tools to adjust or aim.
- Standard 120/347Vac input voltage
- NEXUS® compatible (for more information on NEXUS®, please consult your sales representative)
- CSA C22.2 No. 141 certified



TYPICAL SPECIFICATIONS

Supply and install a complete emergency lighting system as described herein and shown on the drawings.

The Lumacell **Smart Diagnostic** Micro controller board shall supply the rated load for a minimum of a 1/2 hour to 87.5% of the rated battery voltage. The unit shall be rated 120V or 347V, 60 Hz and be CSA listed. The unit shall have an output of _____ volts.

The charger shall be fully computer tested and its charge voltage factory set to $\pm 1\%$ tolerance. Chargers with field-adjusted potentiometers are not acceptable. A pulse-type charger shall be employed to promote long battery life and reduce the potential for grid corrosion. The charger shall provide a continuous high charge to recharge the battery, when the battery is at full capacity, the charger will shut-off. Periodically the charger shall provide a pulse of energy to keep the battery topped off. The charger shall be current limited, temperature compensated, short-circuit proof and reverse polarity protected. The unit shall be furnished with an electronic lockout circuit, which will connect the battery when the AC circuit is activated, and an electronic brownout circuit, which will activate the emergency lights when utility power dips below 75% of nominal voltage.

A low voltage battery protection circuit shall be provided and will disconnect the battery from the fused output circuit at the end of discharge. The unit shall self-test for 1 minute every 30 days, 10 minutes on the 6th month and 30 minutes every 12 months. The unit shall be capable of full recharge in compliance with CSA specifications. The unit shall be furnished with sealed dust tight relay, a test switch and seven diagnostic LED indicator lights to continuously monitor the status of the unit: Battery Failure, Battery Disconnected, Charger Failure, Lamp Failure, Service Alarm, AC "ON", Charger High Rate. The unit shall be T-bar mounted and come complete with tool-less emergency lighting heads requiring no tools to adjust or aim.

The unit shall be **Lumacell** model: _____

CABINET	DIMENSIONS					
	A	B	C	D	E	F
Large Cabinet	23 3/4" (60.3 cm)	7 1/4" (18.4 cm)	7 1/8" (18.1 cm)	10 5/8" (27.0 cm)	5 5/8" (14.3cm)	13" (33.0 cm)
Small Cabinet	23 3/4" (60.3 cm)	7 1/4" (18.4 cm)	4 5/8" (11.7 cm)	10 5/8" (27.0 cm)	3 1/4" (8.3 cm)	13" (33.0 cm)

REPLACEMENT LAMPS

ORDERING CODE	LAMP TYPE	VOLTAGE/WATTAGE
570.0016-L	Mini tungsten (MT9W)	6V - 9W
570.0025-L	Mini tungsten (MT9W)	12V - 9W
570.0045-L	Mini tungsten (MT9W)	24V - 9W

For the complete list, please see the lamp chart on page 196 to 199

DIMENSIONS

Dimensions are approximate and subject to change.

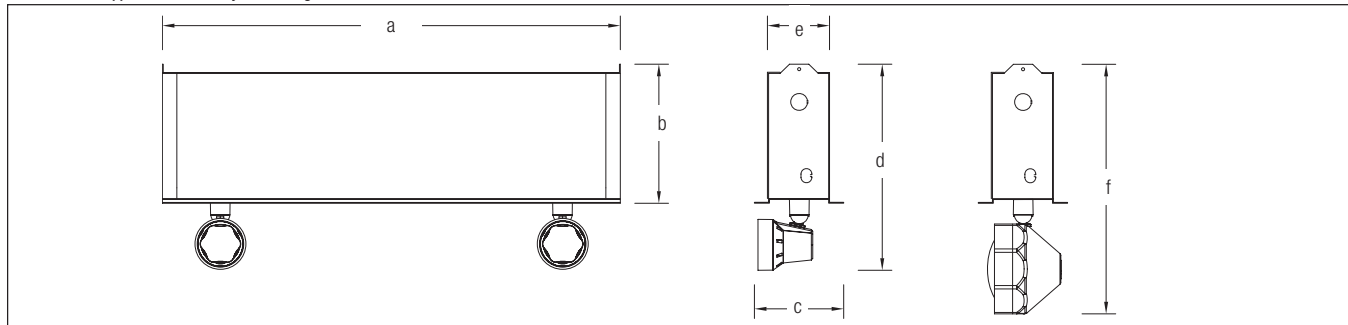

RGS*TB Battery Units

Decorative 6, 12 and 24 volts
T-Bar Unit



RGS*TB SERIES

POWER CONSUMPTION AND UNIT RATING

MODEL	AC SPECS	WATTAGE CAPACITY					
		30MIN	1H00	1H30	2H00	4H00	
RG36TB	120/347Vac	0.10/0.04 Amp	36	21	15	12	6
RG72TB		0.22/0.08 Amp	72	42	30	24	12
RG108TB		0.22/0.08 Amp	108	63	45	36	18
RG180TB		0.22/0.08 Amp	180	105	75	60	30
RG12S36TB		0.09/0.03 Amp	36	21	15	12	6
RG12S72TB		0.15/0.06 Amp	72	42	30	24	12
RG12S100TB		0.34/0.12 Amp	100	58	42	33	17
RG12S144TB		0.40/0.14 Amp	144	84	60	48	24
RG12S200TB		0.41/0.14 Amp	200	117	83	67	33
RG24S144TB		0.55/0.20 Amp	144	84	60	48	24
RG24S288TB		0.67/0.23 Amp	288	168	120	96	48

ORDERING INFORMATION

SERIES	CAPACITY CABINET SIZE	HOUSING	# OF HEADS	HEAD STYLE LAMP WATTAGE	COLOUR	AC VOLTAGE	OPTIONS
RGS= 6 volts	36= 36 watts (P)* 72= 72 watts (P)* 108= 108 watts (P)* 180= 180 watts (G)*	TB= T-Bar	Blank= no head 1= one head 2= two heads 3= three heads	LD1= 6V, 4W, MR16 LED LD7= 12V, 4W, MR16 LED LD13= 24V, 4W, MR16 LED MT9W= mini-tungsten, 6V, 12V, 24V, 9W, wedge base MT18W= mini-tungsten, 12V, 24V, 18W, wedge base MQ8W= mini-halogen, 6V, 12V, 8W, quartz bi-pin MQ12W= mini-halogen, 6V, 12V, 24V, 12W, quartz bi-pin LH9W= tungsten, 6V, 12V, 24V, 9W, wedge base LH18W= tungsten, 12V, 24V, 18W, wedge base LH25W= tungsten, 6V, 12V, 24V, 25W, DCB LHQ8W= halogen, 6V, 12V, 8W, quartz bi-pin LHQ12W= halogen, 6V, 12V, 12W, quartz bi-pin LHQ20W= halogen, 6V, 12V, 24V, 20W, quartz bi-pin LHQ55W= halogen, 12V, 55W*, quartz bi-pin LHQ70W= halogen, 24V, 70W**, quartz bi-pin MQM6W= mini-halogen, 6V, 6W, MR16 MQM10W= mini-halogen, 6V, 10W, MR16 MQM12W= mini-halogen, 12V, 12W, MR16 MQM20W= mini-halogen, 12V, 20W, MR16 SB8W= tungsten, 6V, 8W, 9W, sealed beam SB18W= tungsten, 6V, 12V, 18W, sealed beam SB25W= tungsten, 6V, 12V, 25W, sealed beam QSB8W= halogen, 6V, 12V, 8W, quartz sealed beam QSB12W= halogen, 6V, 12V, 12W, quartz sealed beam QSB20W= halogen, 6V, 20W, quartz sealed beam DR13012W= mini-deco, halogen, 12V, 24V, 12W, MR16 DR13020W= mini deco, halogen, 12V, 24V, 20W, MR16*** DR13035W= mini deco, halogen, 12V, 24V, 35W, MR16*** DR13050W= mini deco, halogen, 12V, 24V, 50W, MR16***	Blank= factory white BK= black *PW= polar white	Blank= 120/347 Vac input ZB= 240Vac Input ZC= 277Vac input ZE= 220 Vac, 50Hz input	Blank= no options A= ammeter AT= auto-test ATN= auto-test non-audible CT= cabtire DPP6= 6cct. fuse panel LD= lamp disconnect LTS= light activated test switch RRT= remote test receiver TD= time delay (programmable) TL= twistlock plug TMBB= AC/DC terminal block TMBD= DC terminal block TMBK= AC terminal block V= voltmeter HHC= remote test transmitter *NEX= NEXUS® system interface *NEXRF= wireless NEXUS® system interface
RG12S= 12 volts	36= 36 watts (P)* 72= 72 watts (P)* 100= 100 watts (P)* 144= 144 watts (P)* 200= 200 watts (G)*						
RG24S= 24 volts	144= 144 watts (G)* 288= 288 watts (G)*						
	* Cabinet size is not part of the ordering information.			*Aluminum heads only. **High temperature heads only. ***Supplied with polar white or black cabinet only.	*With DR head only.		* Consult your sales representative for options available with NEXUS® system.

EXAMPLE: RGS361DR11306W