

# RG\*HZ Series

## Hazardous Locations Battery Unit



### Features

- Certified Class I Division 2, Groups A, B, C and D as per CSA C22.2 No.137-M19811
- Certified Class I Zone 2, Group IIA, B and C
- Certified temperature Codes for several types of emergency lamps
- Suited for areas with the risk of flammable gases, vapors or liquids that can create an explosive atmosphere
- Certified CSA C22.2 No141
- Polymeric frame, with built-in gasket to prevent water infiltration
- Heavy-duty 1/8-inch thick aluminum back plate with key-holes for secure wall-mount installation
- Two MR16 halogen lamps, shielded by a cast Aluminum housing and a polycarbonate cover
- Sealed, maintenance-free, Lead-Calcium batteries with up to 120W emergency power
- Built-in microcontroller-based battery charger and self-test/self-diagnostic circuitry
- 1/2-inch electrical conduit entry on both sides and at the top

NEXUS



Made in Canada



### Typical Specification

Supply and install Lumacell RG-HZ Series of battery units. Designed specifically for hostile environments, the equipment frame shall be of industrial grade polymeric metal with gaskets around both sides of the frame contour. The frame shall be fixed between two plates made of 1/8-inch thick aluminum sheet. The back plate shall include four keyholes for wall-mount installation. The front plate shall include two water-tight lenses for pilot lights: AC-on and "Service required". When specified, the equipment shall have attached a lower compartment containing two emergency lights with adjustable swivels and MR-16 halogen lamps. The lamps shall be shielded by cast aluminum housing and protected by a shock-absorbent, transparent polycarbonate cover.

The equipment shall be certified for Hazardous Locations: Class I Division 2 Groups A, B, C and D. The standard equipment shall have a dual AC input voltage: 120/347Vac and shall be equipped with a magnetic test switch located on the left side of the frame.

The unit shall include self-testing/self-diagnostic functions monitored by a micro-controller and shall automatically self test for one minute every 30 days, 10 minutes in the 6th month and 30 minutes annually. The "Service required" LED shall light when a fault is detected. A four-LED diagnostic display located inside the equipment shall identify the source of the failure (battery, charger circuitry, lamp load).

The battery unit shall be Lumacell model:

\_\_\_\_\_.

Project/Location		Date
Contractor		Prepared by
LUMACELL Model		



## RG\*HZ SERIES

### Dimensions

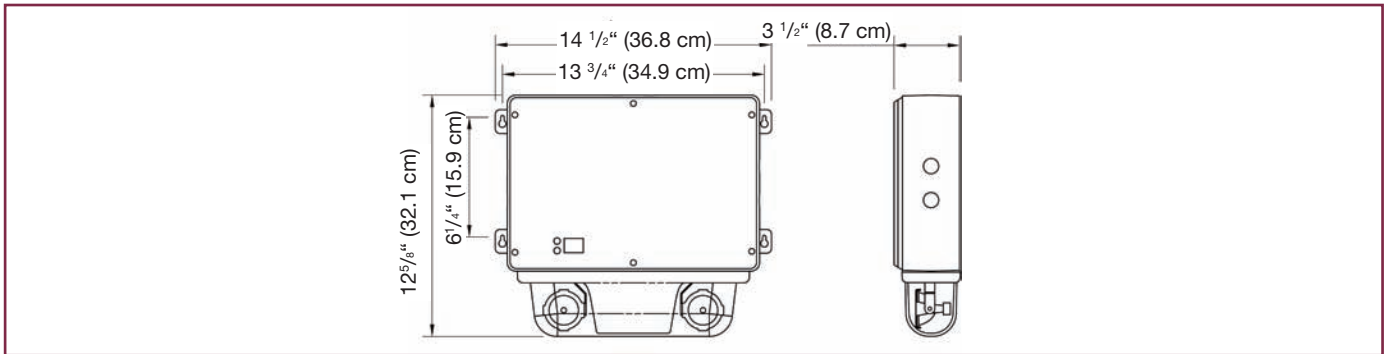

### Temperature Codes

Lamp Rating	Temperature Code	Max. Temperature	Replacement part #
<b>6V 10W</b>	T3C	160 °C	580.0079
<b>12V 12W</b>	T3A	180 °C	580.0080
<b>12V 20W</b>	T2D	215 °C	580.0068

**Note:** Use qualified replacement lamps to avoid risk of over-heating

### Power Consumption and Unit Rating

Model	AC Specs		Wattage Capacity				
			30 min.	1 hr.	1.5 hrs.	2 hrs.	4 hrs.
<b>RGHZ36</b>	120/347 Vac	0.15/0.06 Amp	36	21	15	12	-
<b>RG12HZ72</b>	120/347 Vac	0.30/0.10 Amp	72	42	30	24	12
<b>RG12HZ120</b>	120/347 Vac	0.30/0.10 Amp	120	70	50	40	20

### Ordering Information

Series	Capacity	# of Heads	Lamps	Colour	A.C. Voltage	Options
<b>RGHZ=</b> 6 volts	<b>36=</b> 6V-36W <b>72=</b> 12V-72W	<b>Blank=</b> no heads	<b>M10W=</b> 6V - 10W, MR16	<b>Blank=</b> grey, standard	<b>Blank=</b> 120/347vac <b>ZC=</b> 277vac	<b>AT=</b> auto test, audible
<b>RG12HZ=</b> 12 volts	<b>120=</b> 12V-120W	<b>2=</b> 2 heads	<b>M12W=</b> 12V - 12W, MR16 <b>M20W=</b> 12V - 20W, MR16 high output			<b>ATN=</b> auto Test, non-audible <b>** NEX=</b> NEXUS® system interface

**EXAMPLE: RGHZ362M10WATN**