

# LM\*CS Series - LED Steel Sortie Sign

## Combined with Power Pack

### IMPORTANT SAFEGUARDS

When using electrical equipment, basic safety precautions should always be followed including the following:

### READ AND FOLLOW ALL SAFETY INSTRUCTIONS

1. Do not use outdoors.
2. Do not let power supply cords touch hot surfaces.
3. Do not mount near gas or electric heaters.
4. Use caution when handling batteries. Avoid possible shorting.
5. Equipment should be mounted in locations and at heights where it will not readily be subjected to tampering by unauthorized personnel.
6. The use of accessory equipment not recommended by the manufacturer may cause an unsafe condition.
7. Do not use this equipment for other than intended use.
8. All servicing should be performed by qualified service personnel.

### SAVE THESE INSTRUCTIONS

#### Installation Instructions

1. Turn off AC power.
2. Route AC supply wires into electrical box and leave 15 cm (6") of wire length.
3. Remove stencil face. To open the sign, remove end cap (see fig. 1) and slide out the stencil face and diffuser panel.
4. Remove the appropriate chevron(s) on the exit sign by supporting the exit face on either side of the chevron and carefully knock out with a screwdriver from the rear (see fig. 2).

#### Wall Mount

- a. Knock out the proper hole pattern in the back plate to mount to the standard junction box (including the large wire hole); place a support on either side of the hole to be removed and knock out with a screwdriver.
- b. Feed AC supply leads through the center hole.
- c. Mount the exit sign securely to the junction box using the junction box screws (see fig. 3).

#### Canopy - Ceiling mount

- a. Remove the large wire knockout on top of the frame from the outside with a hammer and a screwdriver.
- b. Route the AC wires from the sign through the large knockout. Make sure backplate is mounted so that the exit face will be facing in the desired direction.
- c. Fasten the spider plate to the junction box using the junction box screws. Align the two threaded holes in the spider plate to line up with the canopy holes for correct mounting position.
- d. Fasten the canopy to the power pack (see fig. 1). Then, fasten the canopy and sign assembly to the spider plate using the provided 1 1/2" screws.

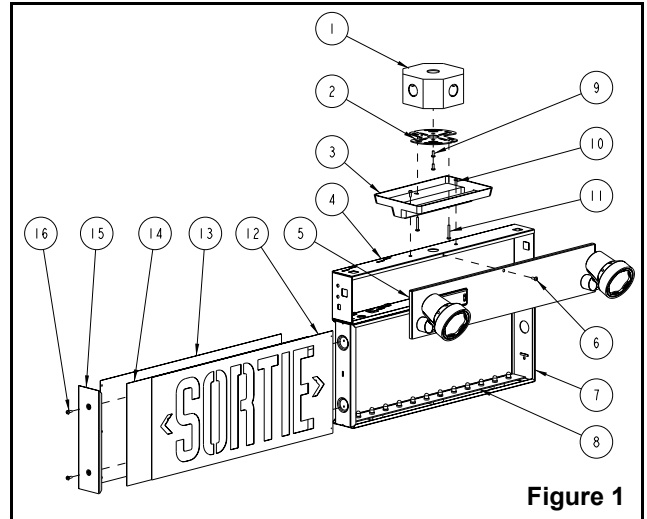

Figure 1

#### Part List

- |                                |                                       |
|--------------------------------|---------------------------------------|
| 1. Junction box (not provided) | 9. Junction box screws (not provided) |
| 2. Spider plate                | 10. Screws #8-32 x 3/8" (2)           |
| 3. Canopy                      | 11. Screws #8-32 x 1 1/2" (2)         |
| a. Plastic: ceiling mount only | 12. Stencil                           |
| b. Metal: universal mount      | 13. Back Plate                        |
| 4. Power Pack                  | 14. Diffuser Panel                    |
| 5. Power Pack cover            | 15. End Cap                           |
| 6. Power Pack cover screw      | 16. Finishing screws (2)              |
| 7. Housing                     |                                       |
| 8. LED strip                   |                                       |

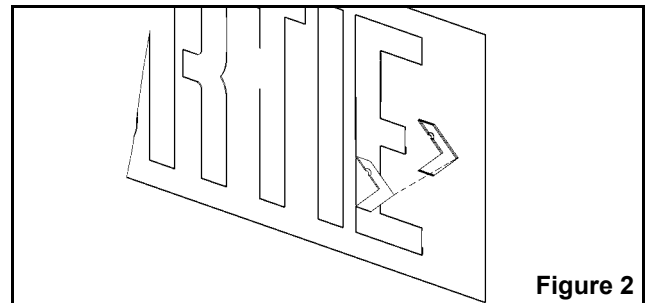

Figure 2

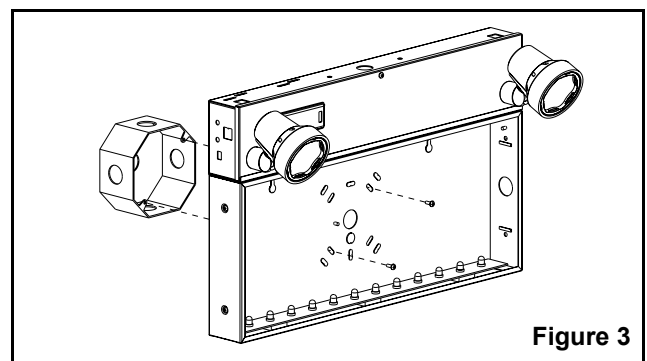

Figure 3

**Canopy - End mount (metal canopy only)**

- a. **WARNING: NEED METAL CANOPY FOR END MOUNT INSTALLATION.**
- b. For end mount installation, refer to instruction sheet included in the end mount metal canopy kit.
- c. Refer to catalog for extra metal canopy part number.
5. Make the proper connections: this unit accepts an input voltages of 120 and 347 VAC. **For 120 VAC:** connect the black wire to AC line voltage (120 VAC) and the white wire to neutral. **For 347 VAC:** connect the red wire to AC line voltage (347 VAC) and the white wire to neutral (see fig. 4). Feed the wire into the junction box. Some models come with wire extensions to ease the connection in wall mount position. Refer to figure 4 color code to connect the extension wires.
6. Connect the green ground wires to the service ground or the ground connection in the junction box.
7. When ready to energize AC, plug in the battery connector to the circuit board. Connect the battery and turn on AC power within 6 hours. Connect the battery and turn on AC power within 6 hours.
8. Slide the diffuser panel, exit face and back plate, if removed, into the housing. Reinstall end cap.
9. Energize AC power.

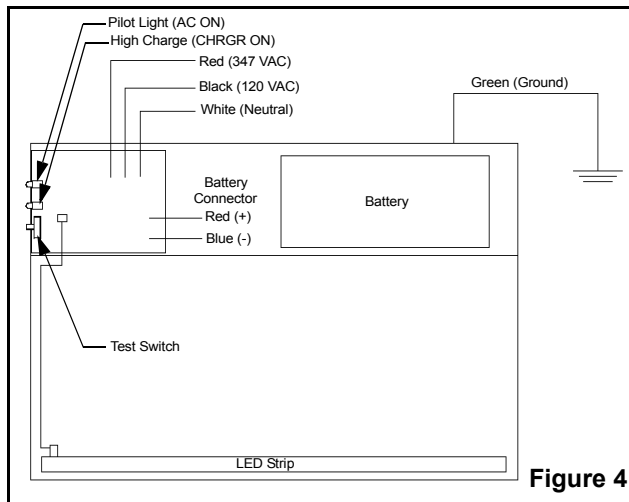

Figure 4

**Deliberate AC Shutdown**

If the AC input power is intentionally turned off for more than 72 hours, disconnect one battery lead to prevent damage to battery. Isolate loose battery lead so that it cannot be inadvertently shorted.

**Battery Replacement**

A battery has reached the end of its useful life when it cannot light lamps for full time rating despite normal charger operation. To replace battery, first disconnect AC power to unit, open unit, disconnect battery leads, then remove it and install new battery. Make sure the red lead connected to battery positive is also connected to charger positive (+) terminal. After unit has been on charge for 24 hours at nominal AC voltage, check that battery voltage is within limits. Refer to markings on battery or unit model for correct replacement type.

**Lamp Replacement**

It is important to replace burned lamp with a new lamp with the same voltage and wattage. Higher wattage will cause battery to discharge faster (less time) or overload relay. Lower wattage may not provide adequate light output.

**Testing**

Once every 3 months the unit should be checked and then tested for at least 30 seconds by using the test switch or disconnecting the plug or pulling the fuse or breaker. Before testing, the green pilot light should be on and the yellow high charge lamp (when supplied) will "wink on" occasionally. After the power has been restored the high charge light will stay on for several minutes then start to "wink" indicating the battery is up to full charge. Once every year the unit should be tested under simulated power failure or electrical fault condition for the time period required by the national Building Code, i.e. 30 m - 1 hr - 2 hrs. After power has been restored, unit will go on high charge for up to 24 hours. If a power failure has occurred recently and the unit worked properly, it is not necessary to perform the simulated failure. Indicate on the charts (see fig. 5) the date of the failures and/or tests performed.

**Caution**

The battery in this unit will hold charge until the date shown on the carton. After this date the unit must be plugged in and battery connected to charger for at least 24 hours to recharge battery. Battery shall then be disconnected. Shelf life will then be good for six months before recharging again. If the unit is not placed into service or re-charged by the date shown on the carton, warranty will be void. The AC power supply shall be unswitched, otherwise warranty will be void. This unit is designed to operate between 10°C and 30°C (50°F and 86°F). Operating temperatures outside those limits will void warranty.

TYPE:	Location:												Full Test
Sr. No.:	Endroit:												Essai complet
Date:	J	F	M	A	M	J	J	A	S	O	N	D	
20													
20													
20													
20													
20													
20													
20													
20													
20													
20													

Figure 5